

COMPAQ

Compaq Presario V3500 and V3700 Notebook
PCs
Maintenance and Service Guide

© Copyright 2007 Hewlett-Packard
Development Company, L.P.

AMD, the AMD Arrow logo, Athlon, Sempron, Turion, and combinations thereof, are trademarks of Advanced Micro Devices, Inc. Bluetooth is a trademark owned by its proprietor and used by Hewlett-Packard Company under license. Intel, Celeron, Core, and Pentium are trademarks or registered trademarks of Intel Corporation or its subsidiaries in the United States and other countries. Microsoft, Windows, and Windows Vista are either trademarks or registered trademarks of Microsoft Corporation in the United States and/or other countries. SD Logo is a trademark of its proprietor.

The information contained herein is subject to change without notice. The only warranties for HP products and services are set forth in the express warranty statements accompanying such products and services. Nothing herein should be construed as constituting an additional warranty. HP shall not be liable for technical or editorial errors or omissions contained herein.

Fourth Edition: November 2007

First Edition: April 2007

Document Part Number: 448076-004

Safety warning notice

- ⚠ **WARNING!** To reduce the possibility of heat-related injuries or of overheating the computer, do not place the computer directly on your lap or obstruct the computer air vents. Use the computer only on a hard, flat surface. Do not allow another hard surface, such as an adjoining optional printer, or a soft surface, such as pillows or rugs or clothing, to block airflow. Also, do not allow the AC adapter to contact the skin or a soft surface, such as pillows or rugs or clothing, during operation. The computer and the AC adapter comply with the user-accessible surface temperature limits defined by the International Standard for Safety of Information Technology Equipment (IEC 60950).
-

Table of contents

1 Product description

2 External component identification

Top components	8
Display components	8
Button and speakers	9
Keys	10
Lights	11
TouchPad	12
Front components	13
Left-side components	14
Rear component	15
Right-side components	16
Bottom components	17

3 Illustrated parts catalog

Serial number location	18
Computer major components	19
Display assembly components	27
Door/Cover Kit	30
Cable Kit	31
Mass storage devices	32
Miscellaneous parts	34
Sequential part number listing	35

4 Removal and replacement procedures

Preliminary replacement requirements	45
Tools required	45
Service considerations	45
Plastic parts	45
Cables and connectors	46
Drive handling	46
Grounding guidelines	47

Electrostatic discharge damage	47
Packaging and transporting guidelines	48
Workstation guidelines	48
Equipment guidelines	49
Unknown user password	50
Component replacement procedures	51
Serial number	51
Computer feet	52
Battery	53
Hard drive	54
WLAN module	57
RTC battery	61
Memory module	62
Optical drive	64
Keyboard	66
Switch cover	69
Display assembly	71
Camera module	77
Top cover	80
TouchPad	83
Wireless switch board	85
Modem module	87
Audio board	88
Bluetooth module	89
USB board	90
Speaker assembly	92
Power connector cable	94
System board	95
ExpressCard assembly	97
Fan/heat sink assembly	100
Processor	103

5 Setup Utility

Starting the Setup Utility	106
Changing the language of the Setup Utility	106
Navigating and selecting in the Setup Utility	107
Displaying system information	107
Restoring default settings in the Setup Utility	107
Using advanced Setup Utility features	108
Closing the Setup Utility	108
Setup Utility menus	108

6 Specifications

Computer specifications	111
14.1-inch, WXGA, BrightView display specifications	112
Hard drive specifications	113
DVD±RW and CD-RW Super Multi Double-Layer Combo Drive specifications	114
System DMA specifications	115
System interrupt specifications—Intel processors	116
System interrupt specifications—AMD processors	117
System I/O address specifications—Intel processors	118
System I/O address specifications—AMD processors	120
System memory map specifications—Intel processors	122
System memory map specifications—AMD processors	123

7 Screw listing

Phillips PM2.0×5.0 captive screw	126
Phillips PM2.5×4.0 screw	127
Phillips PM3.0×4.0 screw	129
Phillips PM2.0×3.0 screw	130
Phillips PM2.5×9.0 screw	132
Black Phillips PM2.5×7.0 screw	134
Black Phillips PM2.0×5.0 screw	136
Black Phillips PM2.5×5.0 screw	138
Silver Phillips PM2.0×2.0 screw	140
Black Phillips PM2.0×4.0 screw	141
Black Phillips PM2.0×3.0 screw	142
Phillips PM2.0×13.0 captive screw	143

8 Backup and Recovery

Recovering system information	144
Backing up your information	144
When to back up	144
Back up suggestions	145
Using system restore points	145
When to create restore points	145
Create a system restore point	145
Restore to a previous date and time	146
Creating recovery discs	146
Reinstalling software programs and drivers	147
Reinstalling preinstalled programs and drivers	147
Reinstalling programs from discs	147
Performing a recovery	148
Recovering from the recovery discs	148
Recovering from the partition on the hard drive	148
Deleting the recovery partition on the hard drive	149

Updating reinstalled software	149
-------------------------------------	-----

9 Connector pin assignments

Audio-out (headphone)	150
Audio-in (microphone)	150
External monitor	151
RJ-11 (modem)	152
RJ-45 (network)	152
S-Video-out	153
Universal Serial Bus	153

10 Power cord set requirements

Requirements for all countries or regions	154
Requirements for specific countries or regions	155

11 Recycling

Battery	156
Display	156

Index	162
--------------------	------------

1 Product description

Category	Description	Full-featured computer models, Intel	Defeated computer models, Intel	Full-featured computer models, AMD	Defeated computer models, AMD
Product Name	Compaq Presario V3500 and V3700 Notebook PC	✓	✓	✓	✓
Processors	Intel® Core™ 2 Duo processors				
	2.20-GHz, 4-MB L2 cache, 800-MHz front side bus (FSB)	✓	✓		
	2.00-GHz, 2-MB L2 cache, 800-MHz FSB	✓	✓		
	1.86-GHz, 1-MB L2 cache, 533-MHz FSB	✓	✓		
	1.50-GHz, 2-MB L2 cache, 667-MHz FSB	✓	✓		
	Intel Core Duo processors				
	T9300 2.50-GHz, 6-MB L2 cache, 800-MHz FSB	✓	✓		
	T8300 2.40-GHz, 3-MB L2 cache, 800-MHz FSB	✓	✓		
	T8100 2.10-GHz, 3-MB L2 cache, 800-MHz FSB	✓	✓		
	T7700 2.40-GHz, 4-MB L2 cache, 800-MHz FSB	✓	✓		
	T7500, 2.20-GHz, 4-MB L2 cache, 800-MHz FSB	✓	✓		
	T7300 2.00-GHz, 4-MB L2 cache, 800-MHz FSB	✓	✓		
	T7250 2.00-GHz, 2-MB L2 cache, 800-MHz FSB	✓	✓		
	T7100 1.8-GHz, 2-MB L2 cache, 800-MHz FSB	✓	✓		
	T5750 2.00-GHz, 2-MB L2 cache, 667-MHz FSB	✓	✓		
	T5550 1.83-GHz, 2-MB L2 cache, 667-MHz FSB	✓	✓		

Category	Description	Full-featured computer models, Intel	Defeatured computer models, Intel	Full-featured computer models, AMD	Defeatured computer models, AMD
	T5450 1.67-GHz, 2-MB L2 cache, 667-MHz FSB	✓	✓		
	T5250 1.5-GHz, 2-MB L2 cache, 667-MHz FSB	✓	✓		
	Intel Pentium® Dual-Core processors:				
	T2370 1.73 GHz, 1-MB L2 cache, 533-MHz FSB	✓	✓		
	T2330 1.60 GHz, 1-MB L2 cache, 533-MHz FSB	✓	✓		
	T2310 1.46-GHz, 1-MB L2 cache, 533-MHz FSB	✓	✓		
	Intel Celeron® M processors:				
	540 1.86-GHz processor, 1-MB L2 cache, 533-MHz FSB	✓	✓		
	530 1.73-GHz, 1-MB L2 cache, 533-MHz FSB	✓	✓		
	AMD processors				
	Turion™ TL-68 2.4-GHz, 1-MB L2 cache, 1600-MHz FSB			✓	✓
	Turion TL-66 2.3-GHz, 1-MB L2 cache, 1600-MHz FSB			✓	✓
	Turion TL-62 2.1-GHz, 1-MB L2 cache, 1600-MHz FSB			✓	✓
	Turion TL-60 2.0-GHz, 1-MB L2 cache, 1600-MHz FSB			✓	✓
	Turion TL-58 1.9-GHz, 1-MB L2 cache, 1600-MHz FSB			✓	✓
	Turion TL-55 1.8-GHz, 512-KB L2 cache, 800-MHz FSB			✓	✓
	Turion MK-38 2.2-GHz, 512-MB L2 cache, 800-MHz FSB			✓	✓
	Athlon™ TK-53 1.7-GHz, 2-GB L2 cache, 1600-MHz FSB			✓	✓
	Sempron™ 3600 2.0-GHz, 256-KB L2 cache, 1600-MHz FSB			✓	✓
Chipset	Northbridge: Intel PM965	✓			
	Northbridge: GM965		✓		
	Southbridge: Intel ICH8m	✓	✓		
	Northbridge: nVidia MCP67M			✓	✓
	Southbridge: nVidia Integrated			✓	✓

Category	Description	Full-featured computer models, Intel	Defeatured computer models, Intel	Full-featured computer models, AMD	Defeatured computer models, AMD
Graphics	nVidia Discrete PCI Express x 16 Graphics ✓ <ul style="list-style-type: none"> nVidia NB8M GS with 64 MB of dedicated video memory (8M x 32 GDDR3 x 2 PCs) with 128 MB of video memory when system memory is less than 1 GB (64 MB + 64 MB Turbo Cache) nVidia NB8M GS with 64 MB of dedicated video memory (8M x 32 GDDR3 x 2 PCs) with 256 MB of video memory when system memory is greater than or equal to 1 GB (64 MB + 192 MB Turbo Cache) <p>System design supports up to 55-W GPU requirement.</p>				
	Mobile Intel Graphics Media Accelerator X3100 ✓ <p>Unified Memory Architecture (UMA) with shared video memory:</p> <ul style="list-style-type: none"> Up to 64 MB on computers with 512 MB or less of system memory Up to 128 MB on computers with more than 512 MB of system memory <p>Memory size is a dynamic change.</p>				
	UMA nVidia ✓ ✓ <p>Unified Memory Architecture (UMA) with shared video memory:</p> <ul style="list-style-type: none"> Up to 64 MB on computers with 512 MB of system memory Up to 256 MB on computers with 1024 MB of system memory Up to 576 MB on computers with more than 2048 MB of system memory 				

Category	Description	Full-featured computer models, Intel	Defeatured computer models, Intel	Full-featured computer models, AMD	Defeatured computer models, AMD
Panel	14.1-inch, WXGA with BrightView	✓	✓	✓	✓
Memory	2 SODIMM slots	✓	✓	✓	✓
	Customer-accessible/upgradable	✓	✓	✓	✓
	Supports up to 4 GB of system RAM			✓	✓
	Supports up to 2 GB of system RAM	✓	✓		
	DDRII PC2-5300 (667-MHz)	✓	✓	✓	✓
	Supports the following configuration: 4096 (2048 x 2)			✓	✓
	Supports the following configurations: <ul style="list-style-type: none"> • 2048 (1024 x 2) • 1536 (1024 + 512) • 1024 (1024 x 1, 512 x 2) • 512 (512 x 1) 	✓	✓	✓	✓
Hard drives	Supports 9.5-mm, 2.5-inch hard drives	✓	✓	✓	✓
	Serial ATA	✓	✓	✓	✓
	Supports the following drives: <ul style="list-style-type: none"> • 320-GB, 5400-rpm • 250-GB, 5400-rpm • 200-GB, 4200-rpm • 160-GB, 5400-rpm • 120-GB, 5400-rpm • 80-GB, 5400-rpm 	✓	✓	✓	✓
Optical drives	Fixed (removal of 1 screw required)	✓	✓	✓	✓
	Parallel ATA	✓	✓	✓	✓
	12.7-mm tray load	✓	✓	✓	✓

Category	Description	Full-featured computer models, Intel	Defeatured computer models, Intel	Full-featured computer models, AMD	Defeatured computer models, AMD
	Supports the following drives: <ul style="list-style-type: none"> DVD±RW and CD-RW Super Multi Double-Layer Combo Drive with LightScribe DVD±RW and CD-RW Super Multi Double-Layer Combo Drive DVD-CD/RW Combo Drive 	√	√	√	√
Diskette drive	Supports external USB drive only	√	√	√	√
Camera	Low-light, VGA camera	√	√	√	√
	Fixed (no tilt)	√	√	√	√
	640 × 480 by 20 frames per second	√	√	√	√
Microphone	2 dual-array microphones with software	√	√	√	√
Audio	HD audio	√	√	√	√
	Supports Windows Vista® Premium Logo requirements	√	√	√	√
	Presario-branded Altec Lansing speakers	√	√	√	√
Modem	56K V.92 data/fax modem	√	√	√	√
	Supports all world-wide certification requirements	√	√	√	√
	Modem cable not included	√	√	√	√
Ethernet	Integrated Marvell E8039 10/100 network interface card (NIC)	√	√	√	√
	Ethernet cable not included	√	√	√	√
Wireless	Integrated wireless local area network (WLAN) options by way of wireless module:				
	Intel PRO Wireless 3945 802.11a/b/g and 802.11b/g with 2 antennae integrated into the display assembly	√	√		
	Intel PRO Wireless 4965 802.11a/b/g/n with 3 antennae integrated into the display assembly @ 2.4 and 5.0 GHz	√	√		

Category	Description	Full-featured computer models, Intel	Defeatured computer models, Intel	Full-featured computer models, AMD	Defeatured computer models, AMD
	Intel WLAN + Bluetooth®	✓	✓		
	Broadcom 4321AGN Wi-Fi Adapter (802.11a/b/g/draft-n) + Bluetooth w/2 antennas			✓	✓
	Broadcom 4321AGN Wi-Fi Adapter (802.11a/b/g/draft-n) w/2 antennas			✓	✓
External media card	One ExpressCard54 slot	✓	✓	✓	✓
	Digital Media Slot, supports SD, MMC, SDIO, MS, MSpro, xD	✓	✓	✓	✓
	Supports miniature versions of SD, MMC, MS Duo with adapter (adapter is not included)	✓	✓	✓	✓
	Supports 2nd Mini-PCle	✓	✓	✓	✓
Ports	Audio-in (mono microphone)	✓	✓	✓	✓
	Audio-out (stereo headphone)	✓	✓	✓	✓
	Consumer infrared	✓	✓	✓	✓
	RJ-11 (modem)	✓	✓	✓	✓
	RJ-45 (Ethernet, includes link and activity lights)	✓	✓	✓	✓
	S-Video-out	✓	✓	✓	✓
	USB (3)	✓	✓	✓	✓
	VGA (Dsub 15-pin)	✓	✓	✓	✓
	1394	✓	✓	✓	✓
	2-pin AC power	✓	✓	✓	✓
Docking	Expansion port 3 supports HP xb3000 Notebook Expansion Base and HP Notebook QuickDock	✓	✓	✓	✓
Keyboard/ pointing devices	14.1-inch keyboard	✓	✓	✓	✓
	TouchPad with 2 buttons and four-way scroll (taps enabled as default)	✓	✓	✓	✓
Power requirements	12-cell 2.20-Ah Li-ion battery	✓	✓	✓	✓
	6-cell 2.55-Ah Li-ion battery	✓	✓	✓	✓
	6-cell 2.20-Ah Li-ion battery	✓	✓	✓	✓

Category	Description	Full-featured computer models, Intel	Defeatured computer models, Intel	Full-featured computer models, AMD	Defeatured computer models, AMD
	65-W AC adapter with localized cable plug support (2-wire plug with ground pin, supports 2-pin DC connector)	√	√	√	√
Security	Security cable slot	√	√	√	√
Operating system	Preinstalled:				
	Configurable Windows Vista embedded "QuickPlay Direct"	√	√		
	Free DOS	√	√	√	√
	Linux (with 802.11 b/g, Combo Drive, or DVD +/- RW)				√
	Windows Vista Business (32-bit)	√	√	√	√
	Windows Vista Home Basic (32-bit)	√	√	√	√
	Windows Vista Premium (32-bit and 64-bit)	√	√	√	√
	Windows Vista Ultimate (64-bit)	√	√		
Serviceability	End-user replaceable parts:				
	AC adapter	√	√	√	√
	Battery (system)	√	√	√	√
	Hard drive	√	√	√	√
	Memory module	√	√	√	√
	Optical drive	√	√	√	√
	WLAN module	√	√	√	√

2 External component identification

Top components

Display components

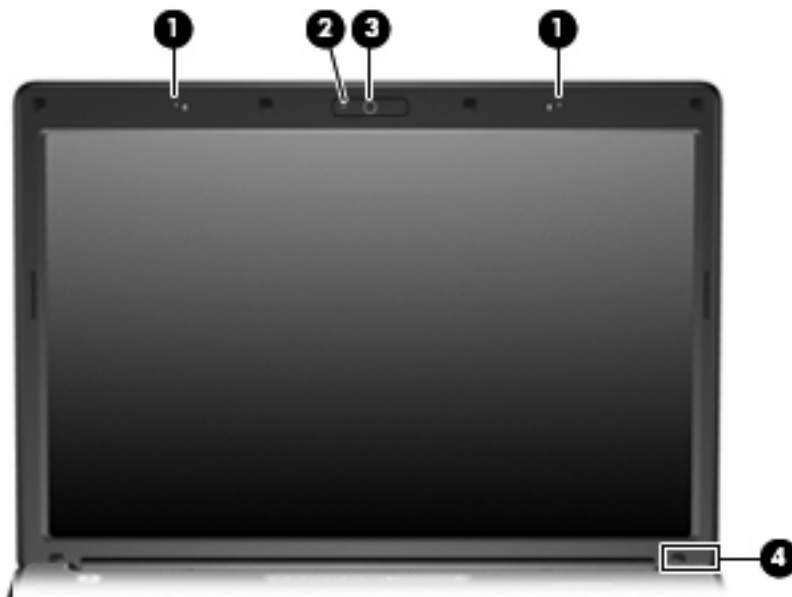

Item	Component	Description
(1)	Internal microphones (2) (select models only)	Record sound. NOTE: If there is a microphone icon next to each microphone opening, your computer has internal microphones.
(2)	Integrated camera light (select models only)	On: The integrated camera is in use.
(3)	Integrated camera (select models only)	Records video and captures still photographs.
(4)	Internal display switch*	Turns off the display if the display is closed while the computer is on.

*The location of the internal display switch varies by computer model.

Button and speakers



Item	Component	Description
(1)	Power button*	<ul style="list-style-type: none"> When the computer is off, press the button to turn on the computer. When the computer is on, press the button to initiate Sleep. When the computer is in the Sleep state, press the button briefly to exit Sleep. When the computer is in Hibernation, press the button briefly to exit Hibernation. <p>If the computer has stopped responding and Windows® shutdown procedures are ineffective, press and hold the power button for at least 5 seconds to turn off the computer.</p> <p>To learn more about power settings, select Start > Control Panel > System and Maintenance > Power Options.</p>
(2)	Speakers (2)	Produce sound.
(3)	Media button	<p>Opens the QuickPlay program.</p> <p>NOTE: If the computer has been set up to require a logon password, you may be asked to log on to Windows. QuickPlay opens after you log on. Refer to the QuickPlay Help for more information.</p>
(4)	Volume mute button	Mutes and restores speaker sound.
(5)	Volume scroll zone	Adjusts speaker volume. Slide your finger to the left to decrease volume and to the right to increase volume. You can also tap the minus sign on the scroll zone to decrease volume, or tap the plus sign on the scroll zone to increase volume.

*This table describes factory settings. For information about changing factory settings, refer to the user guides located in Help and Support.

Keys

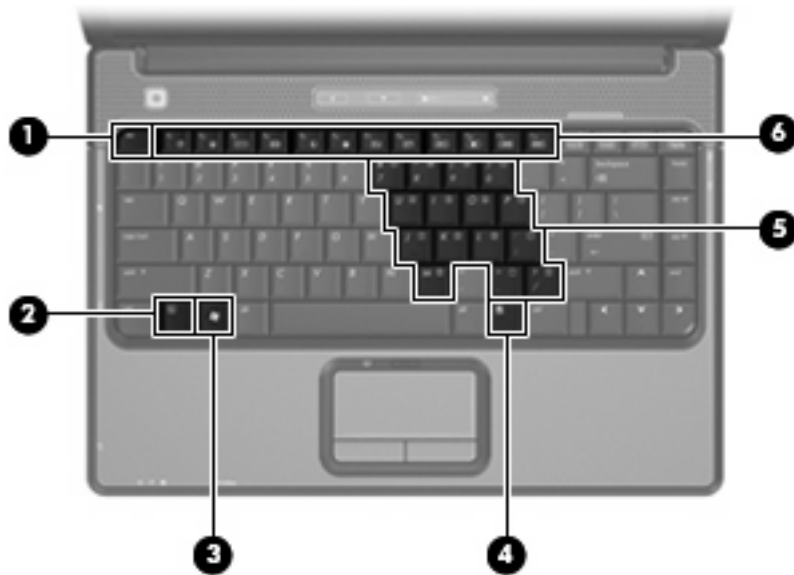

Item	Component	Function
(1)	esc key	Displays system information when pressed in combination with the fn key.
(2)	fn key	Executes frequently used system functions when pressed in combination with a function key or the esc key.
(3)	Windows logo key	Displays the Windows Start menu.
(4)	Windows applications key	Displays a shortcut menu for items beneath the pointer.
(5)	Embedded numeric keypad keys	Can be used like the keys on an external numeric keypad.
(6)	Function keys	Execute frequently used system functions when pressed in combination with the fn key.

Lights



Item	Component	Description
(1)	Power lights (2)*	<ul style="list-style-type: none"> On: The computer is on. Blinking: The computer is in the Sleep state. Off: The computer is off or in Hibernation.
(2)	Battery light	<ul style="list-style-type: none"> On: A battery is charging. Blinking: A battery that is the only available power source has reached a low battery level or a critical battery level. Off: If the computer is plugged into an external power source, the light is turned off when all batteries in the computer are fully charged. If the computer is not plugged into an external power source, the light stays off until the battery reaches a low battery level.
(3)	Drive light	Blinking: The hard drive or optical drive is being accessed.
(4)	Caps lock light	On: Caps lock is on.
(5)	Media button light	Blinks once when the media button is pressed.
(6)	Volume mute light	<ul style="list-style-type: none"> Blue: Computer sound is turned on. Amber: Computer sound is turned off.
(7)	Volume down light	Blinking: The volume scroll zone is being used to decrease speaker volume.
(8)	Volume up light	Blinking: The volume scroll zone is being used to increase speaker volume.
(9)	Num lock light	On: Num lock is on or the embedded numeric keypad is enabled.

*The 2 power lights display the same information. The light on the power button is visible only when the computer is open. The power light on the front of the computer is visible whether the computer is open or closed.

TouchPad

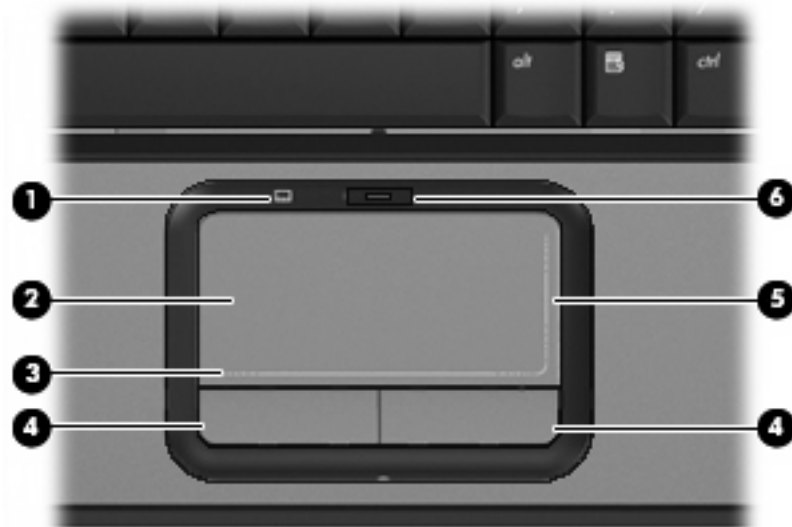

Item	Component	Function
(1)	TouchPad light	<ul style="list-style-type: none">• Blue: TouchPad is enabled.• Amber: TouchPad is disabled.
(2)	TouchPad*	Moves the pointer and selects or activates items on the screen.
(3)	TouchPad horizontal scroll zone	Scrolls left or right.
(4)	Left and right TouchPad buttons*	Function like the left and right buttons on an external mouse.
(5)	TouchPad vertical scroll zone	Scrolls up or down.
(6)	TouchPad on/off button	Enables/disables the TouchPad.

*This table describes factory settings. To view or change pointing device preferences, select **Start > Control Panel > Hardware and Sound > Mouse**.

Front components



Item	Component	Function
(1)	Wireless switch	Turns the wireless feature on or off, but does not create a wireless connection. NOTE: To establish a wireless connection, a wireless network must already be set up.
(2)	Wireless light	<ul style="list-style-type: none"> Blue: An integrated wireless device, such as a WLAN device, and/or a Bluetooth® device, is turned on. Amber: An integrated wireless device is turned off.
(3)	Consumer infrared lens (select models only)	Receives a signal from a remote control device, such as an HP Remote Control.
(4)	Audio-in (microphone)	Connects an optional computer headset microphone, stereo array microphone, or monaural microphone.
(5)	Audio-out (headphone) jack	Produces sound when connected to optional powered stereo speakers, headphones, ear buds, a headset, or television audio.

Left-side components



Item	Component	Function
(1)	S-Video-out jack	Connects an optional S-Video device such as a television, VCR, camcorder, overhead projector, or video capture card.
(2)	External monitor port	Connects an external VGA monitor or projector.
(3)	Expansion port 3	Connects the computer to an optional docking device or optional expansion product. NOTE: The computer has only one expansion port. The term <i>expansion port 3</i> describes the type of expansion port.
(4)	RJ-45 (network) jack	Connects a network cable.
(5)	USB ports (1 or 2, depending on computer model)	Connects optional USB devices.
(6)	1394 port (select models only)	Connects an optional IEEE 1394 or 1394a device, such as a camcorder.
(7)	Digital Media Slot (select models only)	Supports the following optional digital card formats: <ul style="list-style-type: none"> • Memory Stick (MS) • Memory Stick Pro (MSP) • MultiMediaCard (MMC) • Secure Digital Input/Output (SD I/O) • Secure Digital (SD) Memory Card • xDPicture Card (XD) • xD-Picture Card (XD) Type H • xD-Picture Card (XD) Type M
(8)	Digital Media Slot light (select models only)	On: A digital card is being accessed.
(9)	ExpressCard slot	Supports optional ExpressCard/54 cards.

Rear component



Item	Component	Description
(1)	Vent	Enables airflow to cool internal components. NOTE: The computer fan starts up automatically to cool internal components and prevent overheating. It is normal for the internal fan to cycle on and off during routine operation.

Right-side components



Item	Component	Function
(1)	Optical drive	Reads optical discs, and, on select models, also writes to optical discs.
(2)	USB ports (select models only)	Connect optional USB devices.
(3)	RJ-11 (modem) jack	Connects a modem cable.
(4)	Power connector	Connects an AC adapter.
(5)	Security cable slot	Attaches an optional security cable to the computer.

NOTE: The security cable is designed to act as a deterrent, but may not prevent the computer from being mishandled or stolen.

Bottom components

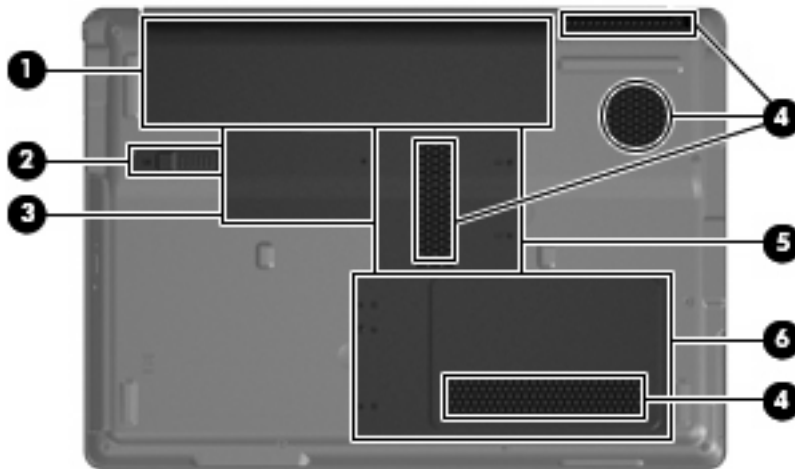

Item	Component	Function
(1)	Battery bay	Holds the battery.
(2)	Battery release latch	Releases the battery from the battery bay.
(3)	Wireless module compartment	Contains a WLAN module slot.
		<p>CAUTION: To prevent an unresponsive system, replace the wireless module only with a wireless module authorized for use in the computer by the governmental agency that regulates wireless devices in your country or region. If you replace the module and then receive a warning message, remove the module to restore computer functionality, and then contact technical support through Help and Support.</p>
(4)	Vents (4)	Enable airflow to cool internal components.
		<p>NOTE: The computer fan starts up automatically to cool internal components and prevent overheating. It is normal for the internal fan to cycle on and off during routine operation.</p>
(5)	Memory module compartment	Contains 2 memory module slots.
(6)	Hard drive bay	Holds the hard drive and the RTC battery.

3 Illustrated parts catalog

Serial number location

When ordering parts or requesting information, provide the computer serial number and model number located on the bottom of the computer.

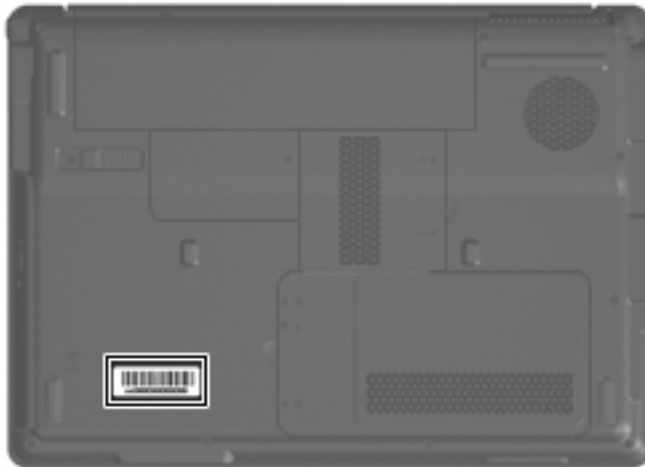

Computer major components

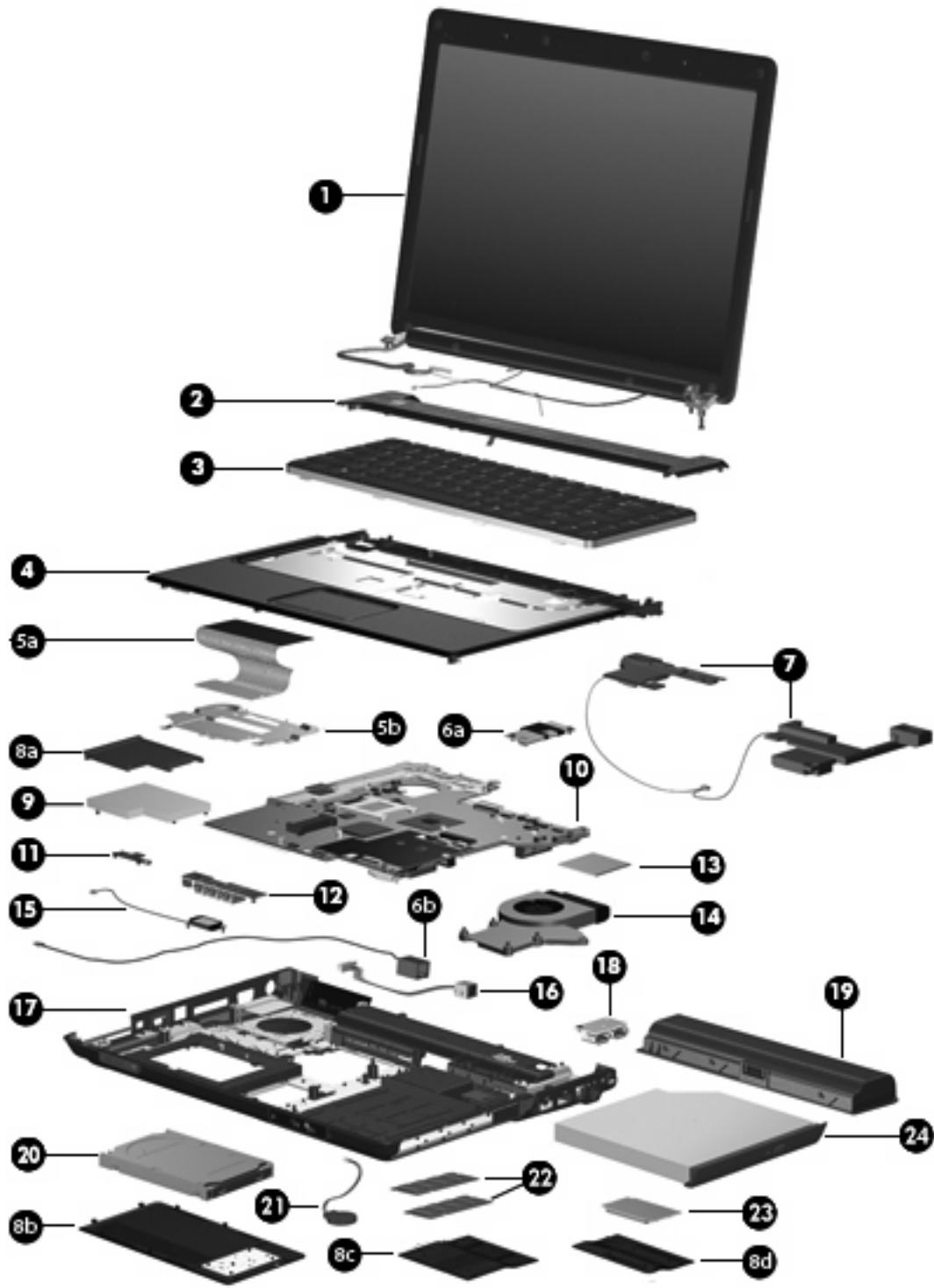

Item	Description	Spare part number
(1)	14.1-inch, WXGA, BrightView display assembly	

Item	Description	Spare part number
	NOTE: See Display assembly components on page 27 for more display assembly internal component spare part information.	
	For use in computer models with Intel or AMD processors without a camera module	448611-001
	For use in defeatured computer models with AMD processors without a camera module	451163-001
	For use in computer models with Intel or AMD processors with a camera module	462761-001
	For use in computer models with Intel or AMD processors without a camera module; does not include microphones	457349-001
(2)	Switch cover (includes power button board and cable, LED board, and LED board cable)	
	For use in computer models with Intel processors or full-featured models with AMD processors	451313-001
	For use in defeatured computer models with AMD processors	417078-001
(3)	Keyboards	
	Belgium	448615-021
	Brazil	448615-201
	Canadian French	448615-121
	Denmark, Finland, Norway, and Sweden	448615-DH1
	France	448615-051
	Germany	448615-041
	Greece	448615-DJ1
	Israel	448615-BB1
	Italy	448615-061
	Latin America	448615-161
	The Netherlands and Europe	448615-B31
	Portugal	448615-131
	Russia	448615-251
	Saudi Arabia	448615-171
	South Korea	448615-AD1
	Spain	448615-071
	Switzerland	448615-111
	Taiwan	448615-AB1
	Thailand	448615-281
	Turkey	448615-141
	The United Kingdom	448615-031
	The United States	448615-001
(4)	Top cover (includes TouchPad and cable)	
	For use only in full-featured computer models with Intel processors and a camera module	462524-001

Item	Description	Spare part number
	For use only in full-featured computer models with Intel processors without a camera module	448620-001
	For use only in full-featured computer models with AMD processors without a camera module	455857-001
	For use only in defeatured computer models with AMD processors without a camera module	417091-001
	For use only in defeatured computer models with Intel processors	460947-001
	For use only in defeatured computer models with Intel processors and a card reader	461267-001
(5a)	TouchPad	
	For use only in computer models with Intel processors	451341-001
	For use only in computer models with AMD processors	455858-001
(5b)	TouchPad bracket (included with top cover)	
(6a)	Modem module (includes modem module cable)	463971-001
(6b)	Modem module cable	455847-001
(7)	Speaker assembly	417089-001
	Door/Cover Kit (see Door/Cover Kit on page 30 for more Door/Cover Kit information)	
(8a)	ExpressCard slot bezel	
(8b)	Hard drive cover	
(8c)	Memory module compartment cover	
(8d)	Wireless module compartment cover	
(9)	ExpressCard assembly	417112-001
(10)	System boards (include thermal material)	
	For use only in computer models with Intel processors:	
	<ul style="list-style-type: none"> Equipped with discrete graphics subsystems and without a camera module 	448596-001
	<ul style="list-style-type: none"> Not equipped with UMA graphics subsystems and without a camera module 	448598-001
	<ul style="list-style-type: none"> Equipped with discrete graphics subsystems and with a camera module 	460716-001
	<ul style="list-style-type: none"> Not equipped with UMA graphics subsystems and with a camera module 	460715-001
	<ul style="list-style-type: none"> On defeatured models 	460717-001
	For use only in computer models with AMD processors:	
	<ul style="list-style-type: none"> Full-featured computer models without a camera module 	453411-001
	<ul style="list-style-type: none"> Defeatured computer models without a camera module 	453412-001
	<ul style="list-style-type: none"> Full-featured computer models with a camera module 	462535-001
	<ul style="list-style-type: none"> Defeatured computer models with a camera module 	462536-001
(11)	Wireless switch board (includes wireless switch board cable)	417092-001
(12)	Audio board (includes audio connectors, infrared lens, and audio board cable)	
	For use only in full-featured computer models without a camera module	459157-001
	For use only in defeatured computer models with AMD processors without a camera module	448627-001

Item	Description	Spare part number
	For use only in full-featured computer models with a camera module	463974-001
	For use only in defeatured computer models with AMD processors with a camera module	463975-001
(13)	Processors (include thermal material)	
	Intel Core 2 Duo processors:	
	• T9300 (2.50-GHz, 6-MB L2 cache)	459799-001
	• T8300 (2.40-GHz, 3-MB L2 cache)	459798-001
	• T8100 (2.10-GHz, 3-MB L2 cache)	459797-001
	• T7700 (2.40-GHz, 4-MB L2 cache)	448148-001
	• T7500 (2.20-GHz, 4-MB L2 cache)	457312-001
	• T7300 (2.00-GHz, 4-MB L2 cache)	448601-001
	• T7250 (2.00-GHz, 2-MB L2 cache)	457311-001
	• T7100 (1.8-GHz, 2-MB L2 cache)	448600-001
	• T5750 (2.00-GHz, 2-MB L2 cache)	462353-001
	• T5550 (1.83-GHz, 2-MB L2 cache)	458247-001
	• T5450 (1.67-GHz, 2-MB L2 cache)	451597-001
	• T5250 (1.50-GHz, 2-MB L2 cache)	453948-001
	Intel Pentium Dual-Core processors:	
	• T2370 (1.73 GHz, 1-MB L2 cache)	462354-001
	• T2330 (1.60 GHz, 1-MB L2 cache)	457314-001
	• T2310 (1.46-GHz, 1-MB L2 cache)	457313-001
	Intel Celeron M processors:	
	• 540 (1.86-GHz, 1-MB L2 cache)	450995-001
	• 530 (1.73-GHz, 1-MB L2 cache)	457315-001
	AMD processors:	
	• Turion TL-68 (2.4-GHz, 1-MB L2 cache)	463917-001
	• Turion TL-66 (2.3-GHz, 1-MB L2 cache)	450804-001 and 453298-001
	• Turion TL-62 (2.1-GHz, 1-MB L2 cache)	455809-001
	• Turion TL-60 (2.0-GHz, 1-MB L2 cache)	455807-001
	• Turion TL-58 (1.9-GHz, 1-MB L2 cache)	448561-001
	• Turion TL-55 (1.86-GHz, 1-MB L2 cache)	455808-001
	• Turion MK-38 (2.2-GHz, 512-MB L2 cache)	449904-001
	• Athlon TK-53 (1.9-GHz, 2-GB L2 cache)	459759-001
	• Athlon TK-53 (1.7-GHz, 2-GB L2 cache)	451013-001
	• Sempron 3800 (2.2-GHz, 256-KB L2 cache)	459760-001

Item	Description	Spare part number
	<ul style="list-style-type: none"> Sempron 3600 (2.0-GHz, 256-KB L2 cache) 	450609-001
(14)	Fan/heat sink assembly (includes thermal material)	
	For use in computer models with AMD processors	455843-001
	For use in computer models with Intel processors	450096-001
	Fan/heat sink mounting bracket (not illustrated)	417114-001
(15)	Bluetooth module (includes Bluetooth module cable)	397923-002
	Bluetooth module cable for use only in computer models with AMD processors (not illustrated)	458663-001
(16)	Power connector cable	
	For use in computer models with Intel processors	448629-001
	For use in computer models with AMD processors	430462-001
(17)	Base enclosure (includes infrared lens and wireless on/off switch)	
	For use only in computer models with Intel processors without a camera module	417094-001
	For use only in defeatured computer models with Intel processors with a camera module	461268-001
	For use only in computer models with AMD processors without a camera module	455850-001
	For use only in defeatured computer models with Intel or AMD processors without a camera module	430470-001
	Rubber Feet Kit (not illustrated; includes base enclosure rubber feet and display bezel screw covers)	417096-001
(18)	USB board (includes USB board cable)	
	For use only in computer models with Intel processors	417085-001
	For use only in computer models with AMD processors	455859-001
(19)	Batteries	
	For use in computer models with Intel or AMD processors:	
	<ul style="list-style-type: none"> 6-cell, 2.55-Ah, Li-ion 	441611-001
	For use only in computer models with Intel processors:	
	<ul style="list-style-type: none"> 12-cell, 2.20-Ah, Li-ion 	452056-001
	<ul style="list-style-type: none"> 6-cell, 2.20-Ah, Li-ion 	452057-001
(20)	Hard drives (include hard drive bracket)	
	For use only in computer models with Intel processors:	
	<ul style="list-style-type: none"> 320-GB, 5400-rpm 	459611-003
	<ul style="list-style-type: none"> 250-GB, 5400-rpm 	453949-001
	<ul style="list-style-type: none"> 200-GB, 4200-rpm 	455740-001
	<ul style="list-style-type: none"> 160-GB, 5400-rpm 	452060-001
	<ul style="list-style-type: none"> 120-GB, 5400-rpm 	452059-001

Item	Description	Spare part number
	<ul style="list-style-type: none"> 80-GB, 5400-rpm 	452058-001
	For use in computer models with AMD processors:	
	<ul style="list-style-type: none"> 320-GB, 5400-rpm 	459611-002
	<ul style="list-style-type: none"> 250-GB, 5400-rpm 	455827-001
	<ul style="list-style-type: none"> 160-GB, 5400-rpm 	453418-001
	<ul style="list-style-type: none"> 120-GB, 5400-rpm 	453417-001
	<ul style="list-style-type: none"> 80-GB, 5400-rpm 	453416-001
	Hard drive hardware kit (contains screws, hard drive bracket, and connector; not illustrated)	453419-001
(21)	RTC battery (includes 2-sided tape)	417076-001
(22)	Memory modules (667-MHz, PC2-5300, 1-DIMM)	
	For use in computer models with Intel processors:	
	<ul style="list-style-type: none"> 2048-MB 	455739-001
	<ul style="list-style-type: none"> 1024-MB 	452062-001
	<ul style="list-style-type: none"> 512-MB 	452061-001
	For use in computer models with AMD processors:	
	<ul style="list-style-type: none"> 2048-MB 	448151-002
	<ul style="list-style-type: none"> 1024-MB 	453415-001
	<ul style="list-style-type: none"> 512-MB 	453414-001
(23)	WLAN modules	
	802.11a/b/g/n WLAN modules:	
	<ul style="list-style-type: none"> For use in Antigua and Barbuda, Argentina, Aruba, the Bahamas, Barbados, Bermuda, Brunei, Canada, the Cayman Islands, Chile, Colombia, Costa Rica, the Dominican Republic, Ecuador, El Salvador, Guam, Guatemala, Haiti, Honduras, Hong Kong, India, Indonesia, Malaysia, Mexico, Panama, Paraguay, Peru, Saudi Arabia, Taiwan, Uruguay, the United States, Venezuela, and Vietnam 	441086-001
	<ul style="list-style-type: none"> For use in Austria, Azerbaijan, Bahrain, Belgium, Brazil, Bulgaria, Croatia, Cyprus, the Czech Republic, Denmark, Egypt, Estonia, Finland, France, Georgia, Germany, Greece, Hungary, Iceland, Ireland, Israel, Italy, Latvia, Lebanon, Liechtenstein, Lithuania, Luxembourg, Malta, Monaco, the Netherlands, Norway, Oman, the Philippines, Poland, Portugal, Qatar, Romania, Russia, Serbia and Montenegro, Singapore, Slovakia, Slovenia, South Africa, Spain, Sri Lanka, Sweden, Switzerland, Turkey, Ukraine, the United Kingdom, and Uzbekistan 	441086-002
	<ul style="list-style-type: none"> For use in Australia, New Zealand, Pakistan, the People's Republic of China, and South Korea 	441086-003
	<ul style="list-style-type: none"> For use in Japan 	441086-291
	<ul style="list-style-type: none"> For use in South Korea 	441086-AD1
	802.11a/b/g WLAN modules:	
	<ul style="list-style-type: none"> For use in Antigua and Barbuda, Argentina, Australia, the Bahamas, Barbados, Brunei, Canada, Chile, the Dominican Republic, Guam, Guatemala, Hong Kong, India, 	452063-001

Item	Description	Spare part number
	Indonesia, Malaysia, Mexico, New Zealand, Panama, Paraguay, Saudi Arabia, Taiwan, the United States, and Vietnam	
	<ul style="list-style-type: none"> For use in Aruba, Austria, Azerbaijan, Bahrain, Belgium, Bermuda, Brazil, Bulgaria, the Cayman Islands, Colombia, Croatia, Cyprus, the Czech Republic, Denmark, Egypt, El Salvador, Estonia, Finland, France, Georgia, Germany, Greece, Hungary, Iceland, Ireland, Italy, Jordan, Latvia, Lebanon, Liechtenstein, Lithuania, Luxembourg, Malta, Monaco, the Netherlands, Norway, Oman, the Philippines, Poland, Portugal, Romania, Russia, Serbia and Montenegro, Singapore, Slovakia, Slovenia, South Africa, Spain, Sri Lanka, Sweden, Switzerland, Turkey, the United Kingdom, and Uzbekistan 	452063-002
	<ul style="list-style-type: none"> For use in Ecuador, Haiti, Honduras, Pakistan, the People's Republic of China, Peru, Qatar, South Korea, Uruguay, and Venezuela 	452063-001
	802.11b/g WLAN module for use in Thailand	409407-004
	Broadcom 4311AG 802.11a/b/g modules:	
	<ul style="list-style-type: none"> For use in the United States and Canada 	441075-001
	<ul style="list-style-type: none"> For use in Afghanistan, Albania, Algeria, Andorra, Angola, Antigua & Barbuda, Argentina, Armenia, Aruba, Australia, Austria, Azerbaijan, the Bahamas, Bahrain, Bangladesh, Barbados, Belarus, Belgium, Belize, Benin, Bermuda, Bhutan, Bolivia, Bosnia & Herzegovina Botswana, Brazil, the British Virgin Islands, Brunei, Bulgaria, Burkina Faso, Burundi, Cambodia, Cameroon, Cape Verde, the Central African Republic, Chad, Chile, Colombia, Comoros, the Congo, Costa Rica, Croatia, Cyprus, the Czech Republic, Denmark, Djibouti, Dominica, the Dominican Republic, East Timor, Ecuador, Egypt, El Salvador, Equatorial Guinea, Eritrea, Estonia, Ethiopia, Fiji, Finland, France, French Guiana, Gabon, Gambia, Georgia, Germany, Ghana, Gibraltar, Greece, Grenada, Guadeloupe, Guatemala, Guinea, Guinea-Bissau, Guyana, Haiti, Honduras, Hong Kong, Hungary, Iceland, India, Indonesia, Ireland, Israel, Italy, the Ivory Coast, Jamaica, Jordan, Kazakhstan, Kenya, Kiribati, Kuwait, Kyrgyzstan, Laos, Latvia, Lebanon, Lesotho, Liberia, Liechtenstein, Lithuania, Luxembourg, Macedonia, Madagascar, Malawi, Malaysia, the Maldives, Mali, Malta, the Marshall Islands, Martinique, Mauritania, Mauritius, Mexico, Micronesia, Monaco, Mongolia, Montenegro, Morocco, Mozambique, Namibia, Nauru, Nepal, the Nether Antilles, the Netherlands, New Zealand, Nicaragua, Niger, Nigeria, Norway, Oman, Palau, Panama, Papua New Guinea, Paraguay, the People's Republic of China, Peru, the Philippines, Poland, Portugal, Qatar, the Republic of Moldova, Romania, Russia, Rwanda, Samoa, San Marino, Sao Tome & Principe, Saudi Arabia, Senegal, Serbia and Montenegro, the Seychelles, Sierra Leone, Singapore, Slovakia, Slovenia, the Solomon Islands, Somalia, South Africa, South Korea, Spain, Sri Lanka, St. Kitts & Nevis, St. Lucia, St. Vincent & the Grenadines, Suriname, Swaziland, Sweden, Switzerland, Taiwan, Tajikistan, Tanzania, Thailand, Togo, Tonga, Trinidad & Tobago, Tunisia, Turkey, Turkmenistan, Tuvalu, Uganda, Ukraine, the United Arab Emirates, the United Kingdom, Uruguay, Uzbekistan, Vanuatu, Venezuela, Vietnam, Yemen, Zaire, Zambia, and Zimbabwe 	441075-002
	<ul style="list-style-type: none"> For use in Japan 	441075-291
	Broadcom 802.11b/g WLAN modules:	
	<ul style="list-style-type: none"> For use in Canada, the Cayman Islands, Guam, Puerto Rico, the U.S. Virgin Islands, and the United States 	441090-001
	<ul style="list-style-type: none"> For use in Afghanistan, Albania, Algeria, Andorra, Angola, Antigua & Barbuda, Argentina, Armenia, Aruba, Australia, Austria, Azerbaijan, the Bahamas, Bahrain, Bangladesh, Barbados, Belarus, Belgium, Belize, Benin, Bermuda, Bhutan, Bolivia, Bosnia & Herzegovina Botswana, Brazil, the British Virgin Islands, Brunei, Bulgaria, Burkina Faso, Burundi, Cambodia, Cameroon, Cape Verde, the Central African Republic, Chad, Chile, Colombia, Comoros, the Congo, Costa Rica, Croatia, Cyprus, the Czech Republic, Denmark, Djibouti, Dominica, the Dominican Republic, East Timor, Ecuador, Egypt, El Salvador, Equatorial Guinea, Eritrea, Estonia, Ethiopia, Fiji, Finland, France, French Guiana, Gabon, Gambia, Georgia, Germany, Ghana, Gibraltar, 	441090-002

Item	Description	Spare part number
	Greece, Grenada, Guadeloupe, Guatemala, Guinea, Guinea-Bissau, Guyana, Haiti, Honduras, Hong Kong, Hungary, Iceland, India, Indonesia, Ireland, Israel, Italy, the Ivory Coast, Jamaica, Jordan, Kazakhstan, Kenya, Kiribati, Kuwait, Kyrgyzstan, Laos, Latvia, Lebanon, Lesotho, Liberia, Liechtenstein, Lithuania, Luxembourg, Macedonia, Madagascar, Malawi, Malaysia, the Maldives, Mali, Malta, the Marshall Islands, Martinique, Mauritania, Mauritius, Mexico, Micronesia, Monaco, Mongolia, Montenegro, Morocco, Mozambique, Namibia, Nauru, Nepal, the Nether Antilles, the Netherlands, New Zealand, Nicaragua, Niger, Nigeria, Norway, Oman, Palau, Panama, Papua New Guinea, Paraguay, the People's Republic of China, Peru, the Philippines, Poland, Portugal, Qatar, the Republic of Moldova, Romania, Russia, Rwanda, Samoa, San Marino, Sao Tome & Principe, Saudi Arabia, Senegal, Serbia and Montenegro, the Seychelles, Sierra Leone, Singapore, Slovakia, Slovenia, the Solomon Islands, Somalia, South Africa, South Korea, Spain, Sri Lanka, St. Kitts & Nevis, St. Lucia, St. Vincent & Grenadines, Suriname, Swaziland, Sweden, Switzerland, Taiwan, Tajikistan, Tanzania, Thailand, Togo, Tonga, Trinidad & Tobago, Tunisia, Turkey, Turkmenistan, Tuvalu, Uganda, Ukraine, the United Arab Emirates, the United Kingdom, Uruguay, Uzbekistan, Vanuatu, Venezuela, Vietnam, Yemen, Zaire, Zambia, and Zimbabwe	
	<ul style="list-style-type: none"> For use in Japan 	441090-291
	802.11n WLAN modules:	
	<ul style="list-style-type: none"> For use in the United States and Canada 	436255-001
	<ul style="list-style-type: none"> For use in the Argentina, Australia, Belize, Bolivia, Brazil, Chile, Columbia, Costa Rica, Ecuador, El Salvador, Guatemala, Honduras, Hong Kong, Indonesia, Nicaragua, Paraguay, the People's Republic of China, Peru, South Korea, Taiwan, Thailand, Uruguay, Venezuela 	436256-001
	<ul style="list-style-type: none"> For use in Japan 	436256-291
	Broadcom BCM4312 WLAN b/g modules:	
	<ul style="list-style-type: none"> For use in Canada, Cayman Islands, Guam, Puerto Rico, the United States, and the Virgin Islands 	459263-001
	<ul style="list-style-type: none"> For use in Afghanistan, Albania, Algeria, Andorra, Angola, Antigua & Barbuda, Argentina, Armenia, Australia, Austria, Azerbaijan, Bahamas, Bahrain, Bangladesh, Barbados, Belarus, Belgium, Belize, Benin, Bhutan, Bolivia, Bosnia & Herzegovina, Botswana, Brazil, Brunei, Bulgaria, Burkina, Faso Burundi, Cambodia, Cameroon, Cape Verde, Central African Republic, Chad, Zaire, Chile, China, Colombia, Comoros, Congo, Costa Rica, Croatia, Cyprus, Czech Republic, Denmark, Djibouti, Dominica, Dominican Republic, Ecuador, Egypt, El Salvador, Equitorial Guinea, Eritrea, Estonia, Ethiopia, Fiji, Finland, France, Gabon, Gambia, Georgia, Germany, Ghana, Gibraltar, Greece, Grenada, Guatemala, Guinea, Guinea-Bissau, Guyana, Haiti, Honduras, Hong Kong, Hungary, Iceland, India, Indonesia, Ireland, Israel, Italy, Ivory Coast, Jamaica, Japan, Jordan, Kazakhstan, Kenya, Kiribati, Kuwait, Kyrgyzstan, Laos, Latvia, Lebanon, Lesotho, Liberia, Martinique, British Virgin Islands, French Guiana, Guadeloupe, Nether Antilles, Aruba, Bermuda, Syria, Liechtenstein, Lithuania, Luxembourg, Macedonia, Madagascar, Malawi, Malaysia, Maldives, Mali, Malta, Marshall Islands, Mauritania, Mauritius, Mexico, Micronesia, Monaco, Mongolia, Montenegro, Morocco, Mozambique, Namibia, Nauru, Nepal, Netherlands, New Zealand, Nicaragua, Niger, Nigeria, Norway, Oman, Pakistan, Palau, Panama, Papua New Guinea, Paraguay, Peru, Philippines, Poland, Portugal, Qatar, Republic of Moldova, Romania, Russia, Rwanda, Samoa, San Marino, Sao Tome & Principe, Saudi Arabia, Senegal, Serbia and Montenegro, Seychelles, Sierra Leone, Singapore, Slovakia, Slovenia, Solomon Islands, Somalia, South Africa, South Korea, Spain, Sri Lanka, St. Kitts & Nevis, St. Lucia, St. Vincent & Grenadines, Suriname, Swaziland, Sweden, Switzerland, Taiwan, Tajikistan, Tanzania, Thailand, East Timor, Togo, Tonga, Trinidad & Tobago, Tunisia, Turkey, Turkmenistan, Tuvalu, Uganda, Ukraine, United Arab Emirates, United Kingdom, Uruguay, Uzbekistan, Vanuatu, Venezuela, Vietnam, Yemen, Zambia, and Zimbabwe 	459263-002

Item	Description	Spare part number
(24)	Optical drives (include bezel)	
	For use in computer models with Intel processors:	
	• DVD±RW and CD-RW Super Multi, Double-Layer Combo Drive with LightScribe	452055-001
	• DVD±RW and CD-RW Super Multi, Double-Layer Combo Drive	452054-001
	• DVD/CD-RW Combo Drive	452053-001
	For use in computer models with AMD processors:	
	• DVD±RW and CD-RW Super Multi Double-Layer Combo Drive with LightScribe	455830-002
	• DVD±RW and CD-RW Super Multi Double-Layer Combo Drive	455829-002
	• DVD/CD-RW Combo Drive	455828-002
	Cable Kit (not illustrated; see Cable Kit on page 31 for more Cable Kit information)	430474-001

Display assembly components

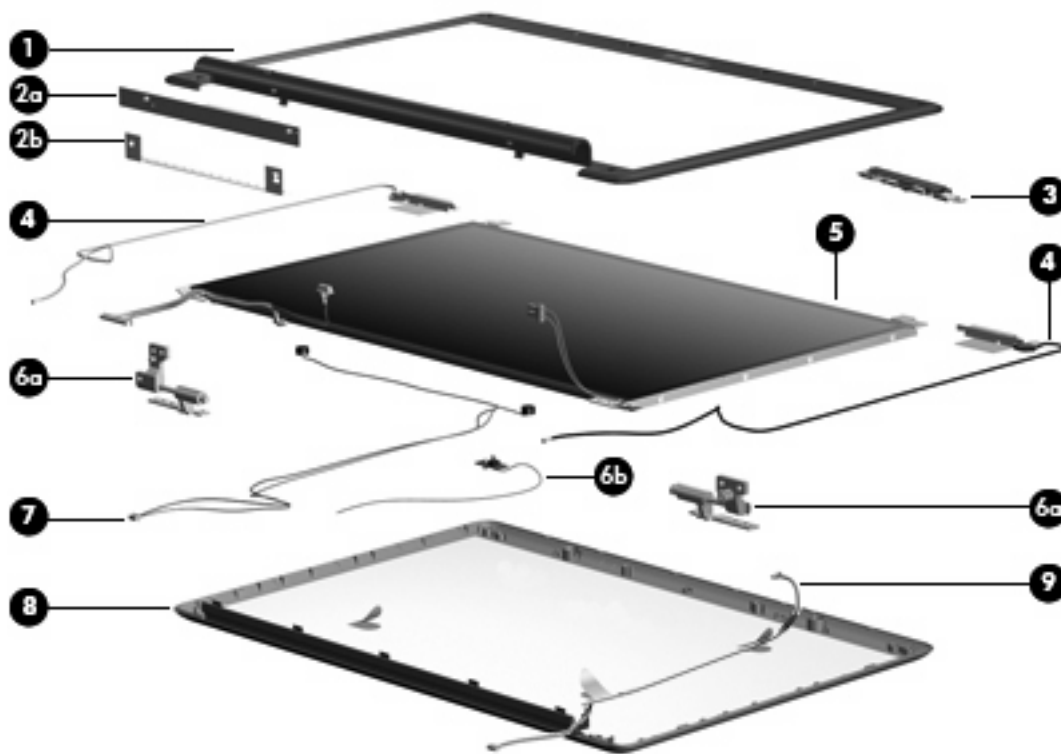

Item	Description	Spare part number
(1)	Display bezels	
	For use with full-featured computer models with Intel processors	462525-001
	For use with defeatured computer models with Intel processors	457351-001

Item	Description	Spare part number
	For use with computer models with Intel or AMD processors without a camera module; includes microphone	448613-001
	For use only with computer models with AMD processors without a camera module; does not include microphone	455820-001
	For use with computer models with AMD processors with a camera module; includes microphone	461913-001
(2a)	Display inverter (includes Mylar shield)	
	For use only with computer models with Intel processors	417097-001
	For use only with computer models with AMD processors	455821-001
(2b)	Display inverter bracket (included with display inverter)	
(3)	Camera module (includes camera module bracket and 2-sided tape)	453673-001
(4)	Wireless Antenna Kit	417107-001
	Antenna, microphone cable kit (not illustrated)	458658-001
(5)	14.1-inch, WXGA, TFT BrightView display panel (includes display panel cable)	
	For use only with computer models with Intel processors	448602-001
	For use only with computer models with AMD processors	455810-001
	Display Hinge Kit	
	For use only with computer models with Intel processors	417103-001
	For use only with computer models with AMD processors	455822-001
(6a)	Left and right display hinges	
(6b)	Display switch module	431881-001
(7)	Display Cable Kit (includes microphones and cables)	
	For use only with computer models with Intel processors with a camera module	462562-001
	For use only with computer models with Intel processors without a camera module	448614-001
	For use only with computer models with AMD processors	458656-001
(8)	Display enclosure	
	For use only with computer models with Intel processors with a camera module	457350-001
	For use only with computer models with Intel processors without a camera module	448612-001
	For use only with computer models with AMD processors without a camera module	455818-001
	For use only with computer models with AMD processors with a camera module	461914-001
(9)	Camera module cable	
	For models only with Intel processors and a camera module	462526-001
	For models only with AMD processors and a camera module	461915-001
	Display Screw Kit (not illustrated; includes screws and rubber screw covers)	
	For use only with computer models with Intel processors	417105-001

Item	Description	Spare part number
	For use only with computer models with AMD processors	455868-001
	Rubber display kit (not illustrated)	458654-001
	Display bracket (not illustrated)	455812-001

Door/Cover Kit

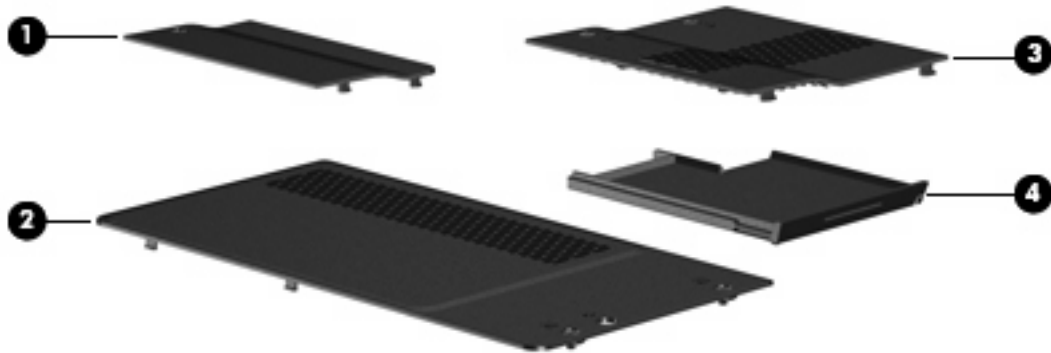

Item	Description	Spare part number
	Door/Cover Kit	417074-001
(1)	Wireless module compartment cover (includes 1 captive screw, secured by a C-clip)	
(2)	Hard drive cover (includes 2 captive screws, secured by C-clips)	
(3)	Memory module compartment cover (includes 2 captive screws, secured by C-clips)	
(4)	ExpressCard slot bezel	

Cable Kit

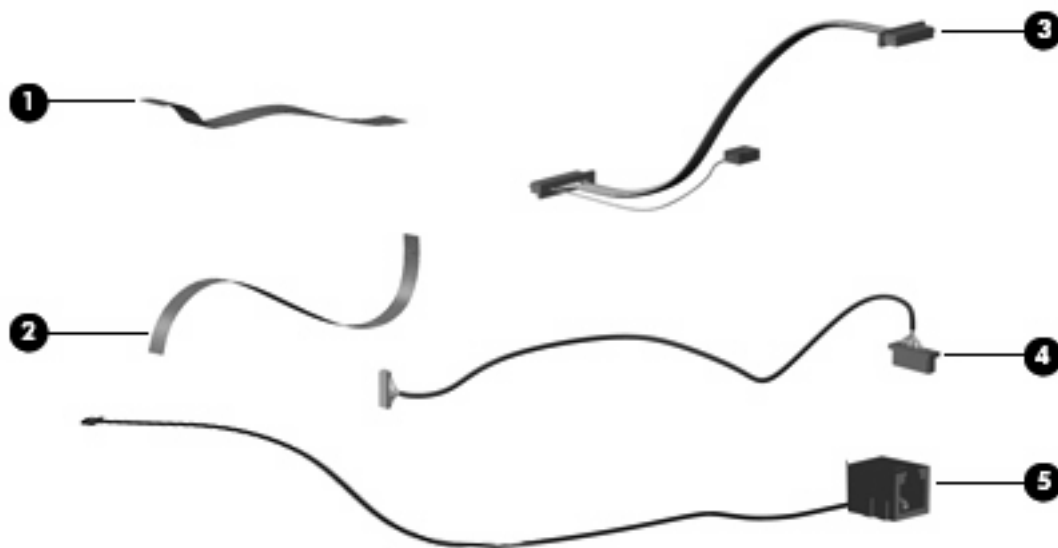

Item	Description	Spare part number
	Cable Kit	430474-001
(1)	Power button board cable	
(2)	LED board cable	
(3)	USB/power connector board cable (includes num lock light)	
(4)	Bluetooth module cable	
(5)	Modem module cable (includes RJ-11 connector)	

Mass storage devices



Item	Description	Spare part number
(1)	Hard drives (include hard drive bracket)	
	For use only in computer models with Intel processors:	
	• 320-GB, 5400-rpm	459611-003
	• 250-GB, 5400-rpm	453949-001
	• 200-GB, 4200-rpm	455740-001
	• 160-GB, 5400-rpm	452060-001
	• 120-GB, 5400-rpm	452059-001
	• 80-GB, 5400-rpm	452058-001
	For use in computer models with AMD processors:	
	• 320-GB, 5400-rpm	459611-002
	• 250-GB, 5400-rpm	455827-001
	• 160-GB, 5400-rpm	453418-001
	• 120-GB, 5400-rpm	453417-001
	• 80-GB, 5400-rpm	453416-001
	Hard drive hardware kit (contains screws, hard drive bracket, and connector; not illustrated)	453419-001
(2)	Optical drives (include bezel and bracket)	
	For use only in computer models with Intel processors:	
	• DVD±RW and CD-RW Super Multi, Double-Layer Combo Drive with LightScribe	452055-001
	• DVD±RW and CD-RW Super Multi, Double-Layer Combo Drive	452054-001
	• DVD/CD-RW Combo Drive	452053-001
	For use in computer models with AMD processors:	

Item	Description	Spare part number
	<ul style="list-style-type: none">• DVD±RW and CD-RW Super Multi Double-Layer Combo Drive with LightScribe	455830-002
	<ul style="list-style-type: none">• DVD±RW and CD-RW Super Multi Double-Layer Combo Drive	455829-002
	<ul style="list-style-type: none">• DVD/CD-RW Combo Drive	455828-002

Miscellaneous parts

Description	Spare part number
AC adapters	
90-W PFC AC adapter	409515-001
65-W PFC AC adapter	417220-001
ATSC/NTSC/PAL TV tuner	439130-001
ATSC/NTSC TV tuner antenna	439131-001
Composite audio and S-Video cable	407939-001
DVB-T tuner	412175-001
DVB-T tuner	412175-002
DVB-T antenna adapter; for use with 412175-001	412176-001
DVB-T antenna adapter; for use with 412175-002	412176-003
Earbud headset	371693-003
HP backpack	405527-001
HP carrying case	418162-001
HP slipcase	458248-001
HP Remote Control for use with computer models with Intel processors	407313-001
HP Remote Control for use with computer models with AMD processors	435743-001
Infrared emitter with cable	439129-001
Optical wired mouse	436238-001
RF input adapter cable (without ferrite)	407940-001
USB digital drive	364727-002
Windows Vista remote control (fits inside ExpressCard slot)	439128-001
Windows Vista remote control (does not fit inside ExpressCard slot)	439254-001
Wireless laser mouse (includes cable adapter)	430958-001
Fingerprint reader	458113-001
Power cords:	
Argentina	383496-D01
Australia and New Zealand	383496-011
Belgium, Europe, Finland, France, Germany, Greece, the Netherlands, Norway, Portugal, Spain, and Sweden	383496-021
Brazil	383496-201
Canada, French Canada, Latin America, Thailand, and the United States	383496-001
Denmark	383496-081
India	383496-D61

Description	Spare part number
Israel	383496-BB1
Italy	383496-061
Japan	383496-291
The People's Republic of China	383496-AA1
South Africa	383496-AR1
South Korea	383496-AD1
Switzerland	383496-111
Taiwan	383496-AB1
The United Kingdom and Hong Kong	383496-031
Screw Kit	
For use in computers with Intel processors	417109-001
For use in computers with AMD processors	455867-001
<ul style="list-style-type: none"> • Phillips PM3.0×4.0 screw • Phillips PM2.5×9.0 screw • Phillips PM2.5×7.0 screw • Phillips PM2.5×5.0 screw • Phillips PM2.5×4.0 screw • Phillips PM2.0×13.0 captive screw • Phillips PM2.0×9.0 captive screw • Phillips PM2.0×8.0 screw • Phillips PM2.0×5.0 screw • Phillips PM2.0×5.0 captive screw • Phillips PM2.0×4.0 screw • Phillips PM2.0×3.0 screw • Phillips PM2.0×2.0 screw 	

Sequential part number listing

Spare part number	Description
364727-002	USB digital drive
371693-003	USB digital drive
383496-001	Power cord for use in the United States
383496-011	Power cord for use in Australia

Spare part number	Description
383496-021	Power cord for use in Europe
383496-031	Power cord for use in the United Kingdom
383496-061	Power cord for use in Italy
383496-081	Power cord for use in Denmark
383496-111	Power cord for use in Switzerland
383496-201	Power cord for use in Brazil
383496-291	Power cord for use in Japan
383496-AA1	Power cord for use in the People's Republic of China
383496-AB1	Power cord for use in Taiwan
383496-AD1	Power cord for use in South Korea
383496-AR1	Power cord for use in South Africa
383496-BB1	Power cord for use in Israel
383496-D01	Power cord for use in Argentina
383496-D61	Power cord for use in India
397923-002	Bluetooth module (includes Bluetooth module cable)
405527-001	HP backpack
407313-001	HP Remote Control for use with computers with Intel processors
407939-001	Composite video cable
407940-001	RF input adapter cable (without ferrite)
408479-002	TV tuner remote control for use in Europe, the Middle East, and Africa
408483-001	USB infrared receiver
409407-004	802.11b/g WLAN module for use in Thailand
409515-001	90-W PFC AC adapter
412175-001	DVB-T tuner
412175-002	DVB-T tuner
412176-001	DVB-T antenna adapter; for use with 412175-001
412176-002	DVB-T antenna and DVB-T antenna adapter
412176-003	DVB TV antenna adapter; for use with 412175-002
417074-001	Door/Cover Kit (see Door/Cover Kit on page 30) for more Door/Cover Kit information)
417076-001	RTC battery (includes 2-sided tape)
417078-001	Switch cover for use in defeatured computer models with AMD processors (includes power button board and cable, LED board, and LED board cable)
417085-001	USB board for use only in computer models with Intel processors (includes USB board cable)
417089-001	Speaker assembly

Spare part number	Description
417091-001	Top cover for use in defeatured computer models with AMD processors (includes TouchPad and cable)
417092-001	Wireless switch board (includes wireless switch board cable)
417094-001	Base enclosure for use only in computer models with Intel processors without a camera module (includes infrared lens and wireless on/off switch)
417096-001	Rubber Feet Kit (includes base enclosure rubber feet and display bezel screw covers)
417097-001	Display inverter for use only in computer models with Intel processors (includes Mylar shield and bracket)
417103-001	Display Hinge Kit for use in computer models with Intel processors (includes left and right display hinges and display switch module)
417105-001	Display Screw Kit for use only in computer models with Intel processors (includes screws and rubber screw covers)
417107-001	Wireless Antenna Kit
417109-001	Screw Kit for use in computer models with Intel processors
417112-001	ExpressCard assembly
417114-001	Fan/heat sink mounting bracket
417220-001	65-W PFC AC adapter
418162-001	HP carrying case
430462-001	Power connector cable for use in computer models with AMD processors
430470-001	Base enclosure for use only in defeatured computer models with Intel or AMD processors without a camera module (includes infrared lens and wireless on/off switch)
430474-001	Cable Kit (see Cable Kit on page 31 for more Cable Kit information)
430958-001	Wireless laser mouse (includes cable adapter)
431881-001	Display switch module
435743-001	HP Remote Control for use with computers with AMD processors
436238-001	Optical wired mouse
436255-001	WLAN 802.11n module for use in the United States and Canada
436256-001	WLAN 802.11n module for use in the Argentina, Australia, Belize, Bolivia, Brazil, Chile, Columbia, Costa Rica, Ecuador, El Salvador, Guatemala, Honduras, Hong Kong, Indonesia, Nicaragua, Paraguay, the People's Republic of China, Peru, South Korea, Taiwan, Thailand, Uruguay, Venezuela
439128-001	Windows Vista remote control (fits inside ExpressCard slot)
439129-001	Infrared emitter with cable
439130-001	ATSC/NTSC/PAL TV tuner
439131-001	ATSC/NTSC TV tuner antenna
439254-001	Windows Vista remote control (does not fit inside ExpressCard slot)
441075-001	Broadcom 4311AG 802.11a/b/g WLAN module for use in the United States and Canada
441075-002	Broadcom 4311AG 802.11a/b/g WLAN module for use in Afghanistan, Albania, Algeria, Andorra, Angola, Antigua & Barbuda, Argentina, Armenia, Aruba, Australia, Austria, Azerbaijan, the Bahamas, Bahrain, Bangladesh, Barbados, Belarus, Belgium, Belize, Benin, Bermuda, Bhutan, Bolivia, Bosnia & Herzegovina, Botswana, Brazil, the British Virgin Islands, Brunei, Bulgaria, Burkina Faso, Burundi, Cambodia, Cameroon,

Spare part number	Description
	Cape Verde, the Central African Republic, Chad, Chile, Colombia, Comoros, the Congo, Costa Rica, Croatia, Cyprus, the Czech Republic, Denmark, Djibouti, Dominica, the Dominican Republic, East Timor, Ecuador, Egypt, El Salvador, Equatorial Guinea, Eritrea, Estonia, Ethiopia, Fiji, Finland, France, French Guiana, Gabon, Gambia, Georgia, Germany, Ghana, Gibraltar, Greece, Grenada, Guadeloupe, Guatemala, Guinea, Guinea-Bissau, Guyana, Haiti, Honduras, Hong Kong, Hungary, Iceland, India, Indonesia, Ireland, Israel, Italy, the Ivory Coast, Jamaica, Jordan, Kazakhstan, Kenya, Kiribati, Kuwait, Kyrgyzstan, Laos, Latvia, Lebanon, Lesotho, Liberia, Liechtenstein, Lithuania, Luxembourg, Macedonia, Madagascar, Malawi, Malaysia, the Maldives, Mali, Malta, the Marshall Islands, Martinique, Mauritania, Mauritius, Mexico, Micronesia, Monaco, Mongolia, Montenegro, Morocco, Mozambique, Namibia, Nauru, Nepal, the Nether Antilles, the Netherlands, New Zealand, Nicaragua, Niger, Nigeria, Norway, Oman, Palau, Panama, Papua New Guinea, Paraguay, the People's Republic of China, Peru, the Philippines, Poland, Portugal, Qatar, the Republic of Moldova, Romania, Russia, Rwanda, Samoa, San Marino, Sao Tome & Principe, Saudi Arabia, Senegal, Serbia and Montenegro, the Seychelles, Sierra Leone, Singapore, Slovakia, Slovenia, the Solomon Islands, Somalia, South Africa, South Korea, Spain, Sri Lanka, St. Kitts & Nevis, St. Lucia, St. Vincent & Grenadines, Suriname, Swaziland, Sweden, Switzerland, Taiwan, Tajikistan, Tanzania, Thailand, Togo, Tonga, Trinidad & Tobago, Tunisia, Turkey, Turkmenistan, Tuvalu, Uganda, Ukraine, the United Arab Emirates, the United Kingdom, Uruguay, Uzbekistan, Vanuatu, Venezuela, Vietnam, Yemen, Zaire, Zambia, and Zimbabwe
441086-001	802.11a/b/g/n WLAN module for use in Antigua and Barbuda, Argentina, Aruba, the Bahamas, Barbados, Bermuda, Brunei, Canada, the Cayman Islands, Chile, Colombia, Costa Rica, the Dominican Republic, Ecuador, El Salvador, Guam, Guatemala, Haiti, Honduras, Hong Kong, India, Indonesia, Malaysia, Mexico, Panama, Paraguay, Peru, Saudi Arabia, Taiwan, Uruguay, the United States, Venezuela, and Vietnam
441086-002	802.11a/b/g/n WLAN module for use in Austria, Azerbaijan, Bahrain, Belgium, Brazil, Bulgaria, Croatia, Cyprus, the Czech Republic, Denmark, Egypt, Estonia, Finland, France, Georgia, Germany, Greece, Hungary, Iceland, Ireland, Israel, Italy, Latvia, Lebanon, Liechtenstein, Lithuania, Luxembourg, Malta, Monaco, the Netherlands, Norway, Oman, the Philippines, Poland, Portugal, Qatar, Romania, Russia, Serbia and Montenegro, Singapore, Slovakia, Slovenia, South Africa, Spain, Sri Lanka, Sweden, Switzerland, Turkey, Ukraine, the United Kingdom, and Uzbekistan
441086-003	802.11a/b/g/n WLAN module for use in Australia, New Zealand, Pakistan, the People's Republic of China, and South Korea
441086-291	802.11a/b/g/n WLAN module for use in Japan
441086-AD1	802.11a/b/g/n WLAN module for use in South Korea
441090-001	Broadcom 802.11b/g WLAN module for use in Canada, the Cayman Islands, Guam, Puerto Rico, the U.S. Virgin Islands, and the United States
441090-002	Broadcom 802.11b/g WLAN module for use in Afghanistan, Albania, Algeria, Andorra, Angola, Antigua & Barbuda, Argentina, Armenia, Aruba, Australia, Austria, Azerbaijan, the Bahamas, Bahrain, Bangladesh, Barbados, Belarus, Belgium, Belize, Benin, Bermuda, Bhutan, Bolivia, Bosnia & Herzegovina Botswana, Brazil, the British Virgin Islands, Brunei, Bulgaria, Burkina Faso, Burundi, Cambodia, Cameroon, Cape Verde, the Central African Republic, Chad, Chile, Colombia, Comoros, the Congo, Costa Rica, Croatia, Cyprus, the Czech Republic, Denmark, Djibouti, Dominica, the Dominican Republic, East Timor, Ecuador, Egypt, El Salvador, Equatorial Guinea, Eritrea, Estonia, Ethiopia, Fiji, Finland, France, French Guiana, Gabon, Gambia, Georgia, Germany, Ghana, Gibraltar, Greece, Grenada, Guadeloupe, Guatemala, Guinea, Guinea-Bissau, Guyana, Haiti, Honduras, Hong Kong, Hungary, Iceland, India, Indonesia, Ireland, Israel, Italy, the Ivory Coast, Jamaica, Jordan, Kazakhstan, Kenya, Kiribati, Kuwait, Kyrgyzstan, Laos, Latvia, Lebanon, Lesotho, Liberia, Liechtenstein, Lithuania, Luxembourg, Macedonia, Madagascar, Malawi, Malaysia, the Maldives, Mali, Malta, the Marshall Islands, Martinique, Mauritania, Mauritius, Mexico, Micronesia, Monaco, Mongolia, Montenegro, Morocco, Mozambique, Namibia, Nauru, Nepal, the Nether Antilles, the Netherlands, New Zealand, Nicaragua, Niger, Nigeria, Norway, Oman, Palau, Panama, Papua New Guinea, Paraguay, the People's Republic of China, Peru, the Philippines, Poland, Portugal, Qatar, the Republic of Moldova, Romania, Russia, Rwanda, Samoa, San Marino, Sao Tome & Principe, Saudi Arabia, Senegal, Serbia and Montenegro, the Seychelles, Sierra Leone, Singapore, Slovakia, Slovenia, the Solomon Islands, Somalia, South Africa, South Korea, Spain, Sri Lanka, St. Kitts & Nevis, St. Lucia, St. Vincent & Grenadines, Suriname, Swaziland, Sweden, Switzerland, Taiwan, Tajikistan, Tanzania, Thailand, Togo, Tonga, Trinidad & Tobago, Tunisia, Turkey, Turkmenistan, Tuvalu, Uganda, Ukraine, the United Arab Emirates, the United Kingdom, Uruguay, Uzbekistan, Vanuatu, Venezuela, Vietnam, Yemen, Zaire, Zambia, and Zimbabwe
441611-001	6-cell, 2.55-Ah battery for use in computer models with Intel or AMD processors

Spare part number	Description
448148-001	Intel Core Duo T7700 2.40-GHz processor, 4-MB L2 cache; includes thermal material
448151-002	2-GB memory module for use in computer models with AMD processors (667-MHz, PC2-5300, 1-DIMM)
448561-001	AMD Turion TL-58 1.9-GHz processor, 1-MB L2 cache; includes thermal material
448596-001	System board for use only with computer models for Intel processors that are equipped with microphones (includes thermal material)
448598-001	System board for use only with computer models with Intel processors that are not equipped with microphones (includes thermal material)
448600-001	Intel Core Duo T7100 1.8-GHz processor (2 MB of L2 cache; includes thermal material)
448601-001	Intel Core Duo T7300 2.0-GHz processor, 4 MB of L2 cache; includes thermal material
448602-001	14.1-inch, WXGA, SVA, TFT BrightView display panel for use only in computer models with Intel processors (includes display panel cable)
448611-001	14.1-inch, WXGA, SVA, TFT BrightView display assembly for use in models without a camera module (includes display panel cable)
448612-001	Display enclosure for use in computer models with Intel processors
448613-001	Display bezel for use in computer models with Intel or AMD processors without a camera module; includes microphone
448614-001	Display Cable Kit for use in computer models with Intel processors (includes microphones and cables)
448615-001	Keyboard for use in the United States
448615-021	Keyboard for use in Belgium
448615-031	Keyboard for use in the United Kingdom
448615-041	Keyboard for use in Germany
448615-051	Keyboard for use in France
448615-061	Keyboard for use in Italy
448615-071	Keyboard for use in Spain
448615-111	Keyboard for use in Switzerland
448615-121	Keyboard for use in French Canada
448615-131	Keyboard for use in Portugal
448615-141	Keyboard for use in Turkey
448615-161	Keyboard for use in Latin America
448615-171	Keyboard for use in Saudi Arabia
448615-201	Keyboard for use in Brazil
448615-251	Keyboard for use in Russia
448615-281	Keyboard for use in Thailand
448615-AB1	Keyboard for use in Taiwan
448615-AD1	Keyboard for use in South Korea
448615-B31	Keyboard for use in the Netherlands and Europe

Spare part number	Description
448615-BB1	Keyboard for use in Israel
448615-DH1	Keyboard for use in Denmark, Finland, Norway, and Sweden
448615-DJ1	Keyboard for use in Greece
448620-001	Top cover for use in full-featured computer models with Intel processors without a camera module (includes TouchPad and cable)
448627-001	Audio board for use only in full-featured computer models without a camera module (includes audio connectors, infrared lens, and audio board cable)
448629-001	Power connector cable for use in computer models with Intel processors
449904-001	AMD Turion MK-38 2.2-GHz processor, 512-MB L2 cache; includes thermal material
450096-001	Fan/heat sink assembly for use in computer models with Intel processors (includes thermal material)
450609-001	AMD Sempron 3600 2.0-GHz processor, 256-KB L2 cache; includes thermal material
450804-001	Turion TL-66 2.3-GHz processor, 1-GB L2 cache; includes thermal material
450995-001	Intel Celeron M 540 1.86-GHz processor, 1-MB L2 cache; includes thermal material
451013-001	Athlon TK-53 1.7-GHz processor, 2-GB L2 cache; includes thermal material
451163-001	14.1-inch, WXGA, SVA, TFT BrightView display assembly for use only in defeatured computer models with AMD processors (includes display panel cable)
451313-001	Switch cover for use in computer models with Intel processors or full-featured models with AMD processors (includes power button board and cable, LED board, and LED board cable)
451341-001	TouchPad for use only in computer models with Intel processors
451597-001	Intel Core Duo T5450 1.67-GHz processor, 2-MB L2 cache; includes thermal material
452053-001	DVD/CD-RW Combo Drive for use only in computer models with Intel processors (includes bezel and bracket)
452054-001	DVD±RW and CD-RW Super Multi Double-Layer Combo Drive for use only in computer models with Intel processors (includes bezel and bracket)
452055-001	DVD±RW and CD-RW Super Multi Double-Layer Combo Drive with LightScribe for use only in computer models with Intel processors (includes bezel and bracket)
452056-001	12-cell, 8.80-Ah battery for use only in computer models with Intel processors
452057-001	6-cell, 2.20-Ah battery for use only in computer models with Intel processors
452058-001	80-GB, 5400-rpm hard drive for use only in computer models with Intel processors (includes hard drive bracket)
452059-001	120-GB, 5400-rpm hard drive for use only in computer models with Intel processors (includes hard drive bracket)
452060-001	160-GB, 5400-rpm hard drive for use only in computer models with Intel processors (includes hard drive bracket)
452061-001	512-MB memory module for use only in computer models with Intel processors (667-MHz, PC2-5300, 1-DIMM)
452062-001	1024-MB memory module for use only in computer models with Intel processors (667-MHz, PC2-5300, 1-DIMM)
452063-001	802.11a/b/g WLAN module for use in Antigua and Barbuda, Argentina, Australia, the Bahamas, Barbados, Brunei, Canada, Chile, the Dominican Republic, Guam, Guatemala, Hong Kong, India, Indonesia, Malaysia, Mexico, New Zealand, Panama, Paraguay, Saudi Arabia, Taiwan, the United States, and Vietnam
452063-002	802.11a/b/g WLAN module for use in Aruba, Austria, Azerbaijan, Bahrain, Belgium, Bermuda, Brazil, Bulgaria, the Cayman Islands, Colombia, Croatia, Cyprus, the Czech Republic, Denmark, Egypt, El Salvador,

Spare part number	Description
	Estonia, Finland, France, Georgia, Germany, Greece, Hungary, Iceland, Ireland, Italy, Jordan, Latvia, Lebanon, Liechtenstein, Lithuania, Luxembourg, Malta, Monaco, the Netherlands, Norway, Oman, the Philippines, Poland, Portugal, Romania, Russia, Serbia and Montenegro, Singapore, Slovakia, Slovenia, South Africa, Spain, Sri Lanka, Sweden, Switzerland, Turkey, the United Kingdom, and Uzbekistan
452063-003	802.11a/b/g WLAN module for use in Ecuador, Haiti, Honduras, Pakistan, the People's Republic of China, Peru, Qatar, South Korea, Uruguay, and Venezuela
453298-001	AMD Turion TL-66 2.3-GHz processor, 1-GB L2 cache; includes thermal material
453411-001	System board for use only with full-featured computer models with AMD processors without a camera module
453412-001	System board for use only with defeatured computer models with AMD processors without a camera module
453414-001	512-MB memory module for use in computer models with AMD processors (667-MHz, PC2-5300, 1-DIMM)
453415-001	1-GB memory module for use in computer models with AMD processors (667-MHz, PC2-5300, 1-DIMM)
453416-001	80-GB hard drive for use in computer models with AMD processors
453417-001	120-GB hard drive for use in computer models with AMD processors
453418-001	160-GB hard drive for use in computer models with AMD processors
453419-001	Hard drive hardware kit for use in computer models with AMD processors (contains screws, hard drive bracket, and connector)
453673-001	Camera module
453948-001	Intel Core Duo T5250 1.50-GHz processor, 2-MB L2 cache; includes thermal material
453949-001	200-GB, 4200-rpm hard drive (includes hard drive bracket)
455739-001	2048-MB memory module for use only in computer models with Intel processors (667-MHz, PC2-5300, 1-DIMM)
455740-001	250-GB, 5400-rpm hard drive (includes hard drive bracket)
455807-001	AMD Turion TL-60 2.00-GHz, processor, 1-MB L2 cache; includes thermal material
455808-001	AMD Turion TL-55 1.86-GHz processor, 1-MB L2 cache; includes thermal material
455809-001	AMD Turion TL-62 2.10-GHz processor, 1-MB L2 cache; includes thermal material
455810-001	14.1-inch, WXGA, BrightView display panel for use in computer models with AMD processors (includes display panel cable)
455812-001	Display bracket
455818-001	Display enclosure for use in computer models with AMD processors without a camera module
455820-001	Display bezel without microphone for use only in computer models with AMD processors
455821-001	Display inverter for use only in computer models with AMD processors (includes Mylar shield and bracket)
455822-001	Display Hinge Kit for use in computer models with AMD processors (includes left and right display hinges and display switch module)
455827-001	250-GB hard drive for use in computer models with AMD processors
455828-002	DVD/CD-RW Combo Drive for use in computer models with AMD processors (includes bezel and bracket)
455829-002	DVD±RW and CD-RW Super Multi Double-Layer Combo Drive for use in computer models with AMD processors (includes bezel and bracket)
455830-002	DVD±RW and CD-RW Super Multi Double-Layer Combo Drive with LightScribe for use in computer models with AMD processors (includes bezel and bracket)

Spare part number	Description
455843-001	Fan/heat sink assembly for use in computer models with AMD processors (includes thermal material)
455847-001	Modem module cable
455850-001	Base enclosure for use only in computer models with AMD processors without a camera module (includes infrared lens and wireless on/off switch)
455857-001	Top cover for use in full-featured computer models with AMD processors (includes TouchPad and cable)
455858-001	TouchPad for use only in computer models with AMD processors
455859-001	USB board for use only in computer models with AMD processors (includes USB board cable)
455867-001	Screw Kit for use in computer models with AMD processors
455868-001	Display Screw Kit for use only in computer models with AMD processors (includes screws and rubber screw covers)
457311-001	Intel Core Duo T7250 2.00-GHz processor, 2-MB L2 cache; includes thermal material
457312-001	Intel Core Duo T7500 2.20-GHz processor, 4-MB L2 cache; includes thermal material
457313-001	Intel Pentium Dual Core T2310 1.46-GHz processor, 1-MB L2 cache; includes thermal material
457314-001	Intel Pentium Dual Core T2330 1.60-GHz processor, 1-MB L2 cache; includes thermal material
457315-001	Intel Celeron M 530 1.73-GHz processor, 1-MB L2 cache; includes thermal material
457348-001	14.1-inch, WXGA, SVA, TFT BrightView display assembly for use in models with Intel or AMD processors without a camera module (includes display panel cable; includes microphones)
457349-001	14.1-inch, WXGA, SVA, TFT BrightView display assembly for use in models with Intel or AMD processors without a camera module (includes display panel cable; does not include microphones)
457350-001	Display enclosure for use in computer models with Intel processors with a camera module
457351-001	Display bezel for use in defeatured computer models with Intel processors
458113-001	Fingerprint reader
458247-001	Intel Core Duo T5750 2.00-GHz processor, 2-MB L2 cache; includes thermal material
458248-001	HP slipcase
458654-001	Rubber display kit
458656-001	Display Cable Kit for use in computer models with AMD processors (includes microphones and cables)
458658-001	Antenna, microphone cable kit for use in models without a camera module
458663-001	Bluetooth module cable for use only in computer models with AMD processors
459157-001	Audio board for use only in defeatured computer models with AMD processors without a camera module (includes audio connectors, infrared lens, and audio board cable)
459263-001	Broadcom BCM4312 WLAN b/g module for use in Canada, Cayman Islands, Guam, Puerto Rico, the United States, and the Virgin Islands
459263-002	Broadcom BCM4312 WLAN b/g modules for use in Afghanistan, Albania, Algeria, Andorra, Angola, Antigua & Barbuda, Argentina, Armenia, Australia, Austria, Azerbaijan, Bahamas, Bahrain, Bangladesh, Barbados, Belarus, Belgium, Belize, Benin, Bhutan, Bolivia, Bosnia & Herzegovina, Botswana, Brazil, Brunei, Bulgaria, Burkina, Faso Burundi, Cambodia, Cameroon, Cape Verde, Central African Republic, Chad, Chile, People's Republic of China, Colombia, Comoros, Congo, Costa Rica, Croatia, Cyprus, Czech Republic, Zaire, Denmark, Djibouti, Dominica, Dominican Republic, Ecuador, Egypt, El Salvador, Equatorial Guinea, Eritrea, Estonia, Ethiopia, Fiji, Finland, France, Gabon, Gambia, Georgia, Germany, Ghana, Gibraltar, Greece, Grenada, Guatemala, Guinea, Guinea-Bissau, Guyana, Haiti, Honduras, Hong Kong, Hungary, Iceland, India, Indonesia,

Spare part number	Description
	Ireland, Israel, Italy, Ivory Coast, Jamaica, Japan, Jordan, Kazakhstan, Kenya, Kiribati, Kuwait, Kyrgyzstan, Laos, Latvia, Lebanon, Lesotho, Liberia, Martinique, British Virgin Islands, French Guiana, Guadeloupe, Nether Antilles, Aruba, Bermuda, Syria, Liechtenstein, Lithuania, Luxembourg, Macedonia, Madagascar, Malawi, Malaysia, Maldives, Mali, Malta, Marshall Islands, Mauritania, Mauritius, Mexico, Micronesia, Monaco, Mongolia, Montenegro, Morocco, Mozambique, Namibia, Nauru, Nepal, Netherlands, New Zealand, Nicaragua, Niger, Nigeria, Norway, Oman, Pakistan, Palau, Panama, Papua New Guinea, Paraguay, Peru, Philippines, Poland, Portugal, Qatar, Republic of Moldova, Romania, Russia, Rwanda, Samoa, San Marino, Sao Tome & Principe, Saudi Arabia, Senegal, Serbia and Montenegro, Seychelles, Sierra Leone, Singapore, Slovakia, Slovenia, Solomon Islands, Somalia, South Africa, South Korea, Spain, Sri Lanka, St. Kitts & Nevis, St. Lucia, St. Vincent & Grenadines, Suriname, Swaziland, Sweden, Switzerland, Taiwan, Tajikistan, Tanzania, Thailand, East Timor, Togo, Tonga, Trinidad & Tobago, Tunisia, Turkey, Turkmenistan, Tuvalu, Uganda, Ukraine, United Arab Emirates, United Kingdom, Uruguay, Uzbekistan, Vanuatu, Venezuela, Vietnam, Yemen, Zambia, and Zimbabwe
459611-002	320-GB, 5400-rpm hard drive for use in computer models with AMD processors (includes hard drive bracket)
459611-003	320-GB, 5400-rpm hard drive for use in computer models with Intel processors (includes hard drive bracket)
459759-001	AMD Athlon TK-57 1.9-GHz processor, 2-GB L2 cache; includes thermal material
459760-001	AMD Sempron 3800 2.2-GHz processor, 256-KB L2 cache; includes thermal material
459797-001	Intel Core Duo T8100 2.10-GHz processor, 3-MB L2 cache; includes thermal material
459798-001	Intel Core Duo T8300 2.40-GHz processor, 3-MB L2 cache; includes thermal material
459799-001	Intel Core Duo T9300 2.50-GHz processor, 6-MB L2 cache; includes thermal material
460715-001	System board for use only with computer models with Intel processors that are not equipped with UMA graphics subsystems and with a camera module (includes thermal material)
460716-001	System board for use only with computer models with Intel processors that are equipped with discrete graphics subsystems and with a camera module (includes thermal material)
460947-001	Top cover for use in defeatured computer models with Intel processors (includes TouchPad and cable)
460717-001	System board for use only with defeatured computer models with Intel processors (includes thermal material)
461267-001	Top cover for use in defeatured computer models with Intel processors and a card reader (includes TouchPad and cable)
461268-001	Base enclosure for use only in defeatured computer models with Intel processors with a camera module (includes infrared lens and wireless on/off switch)
461913-001	Display bezel for use in computer models with AMD processors with a camera module; includes microphone
461914-001	Display enclosure for use in computer models with AMD processors with a camera module
461915-001	Antenna- microphone cable kit for use in models with AMD processors and a camera module
462353-001	Intel Dual Core T5750 2.00-GHz processor, 2-MB L2 cache; includes thermal material
462354-001	Intel Pentium Dual Core T2370 1.73-GHz processor, 1-MB L2 cache; includes thermal material
462524-001	Top cover for use in full-featured computer models with Intel processors and a camera module (includes TouchPad and cable)
462525-001	Display bezel for use in full-featured computer models with Intel processors
462526-001	Antenna-microphone cable kit for use in models with Intel processors and with a camera module
462535-01	System board for use only with full-featured computer models with AMD processors with a camera module
462761-001	14.1-inch, WXGA, SVA, TFT BrightView display assembly for use in models with Intel or AMD processors and a camera module (includes display panel cable)

Spare part number	Description
463536-001	System board for use only with defeatured computer models with AMD processors with a camera module
463917-001	AMD Turion TL-68 2.4-GHz processor, 1-GB L2 cache; includes thermal material
463971-001	Modem module (includes modem module cable)
463974-001	Audio board for use only in full-featured computer models with a camera module (includes audio connectors, infrared lens, and audio board cable)
463975-001	Audio board for use only in defeatured computer models with AMD processors with a camera module (includes audio connectors, infrared lens, and audio board cable)

4 Removal and replacement procedures

Preliminary replacement requirements

Tools required

You will need the following tools to complete the removal and replacement procedures:

- Flat-bladed screwdriver
- Magnetic screwdriver
- Phillips P0 and P1 screwdrivers

Service considerations

The following sections include some of the considerations that you must keep in mind during disassembly and assembly procedures.

 **NOTE:** As you remove each subassembly from the computer, place the subassembly (and all accompanying screws) away from the work area to prevent damage.

Plastic parts

Using excessive force during disassembly and reassembly can damage plastic parts. Use care when handling the plastic parts. Apply pressure only at the points designated in the maintenance instructions.

Cables and connectors

-
- △ **CAUTION:** When servicing the computer, be sure that cables are placed in their proper locations during the reassembly process. Improper cable placement can damage the computer.
-

Cables must be handled with extreme care to avoid damage. Apply only the tension required to unseat or seat the cables during removal and insertion. Handle cables by the connector whenever possible. In all cases, avoid bending, twisting, or tearing cables. Be sure that cables are routed in such a way that they cannot be caught or snagged by parts being removed or replaced. Handle flex cables with extreme care; these cables tear easily.

Drive handling

-
- △ **CAUTION:** Drives are fragile components that must be handled with care. To prevent damage to the computer, damage to a drive, or loss of information, observe these precautions:
-

Before removing or inserting a hard drive, shut down the computer. If you are unsure whether the computer is off or in Hibernation, turn the computer on, and then shut it down through the operating system.

Before handling a drive, be sure that you are discharged of static electricity. While handling a drive, avoid touching the connector.

Before removing a diskette drive or optical drive, be sure that a diskette or disc is not in the drive and be sure that the optical drive tray is closed.

Handle drives on surfaces covered with at least one inch of shock-proof foam.

Avoid dropping drives from any height onto any surface.

After removing a hard drive, an optical drive, or a diskette drive, place it in a static-proof bag.

Avoid exposing a hard drive to products that have magnetic fields, such as monitors or speakers.

Avoid exposing a drive to temperature extremes or liquids.

If a drive must be mailed, place the drive in a bubble pack mailer or other suitable form of protective packaging and label the package "FRAGILE."

Grounding guidelines

Electrostatic discharge damage

Electronic components are sensitive to electrostatic discharge (ESD). Circuitry design and structure determine the degree of sensitivity. Networks built into many integrated circuits provide some protection, but in many cases, ESD contains enough power to alter device parameters or melt silicon junctions.

A discharge of static electricity from a finger or other conductor can destroy static-sensitive devices or microcircuitry. Even if the spark is neither felt nor heard, damage may have occurred.

An electronic device exposed to ESD may not be affected at all and can work perfectly throughout a normal cycle. Or the device may function normally for a while, then degrade in the internal layers, reducing its life expectancy.

△ **CAUTION:** To prevent damage to the computer when you are removing or installing internal components, observe these precautions:

Keep components in their electrostatic-safe containers until you are ready to install them.

Use nonmagnetic tools.

Before touching an electronic component, discharge static electricity by using the guidelines described in this section.

Avoid touching pins, leads, and circuitry. Handle electronic components as little as possible.

If you remove a component, place it in an electrostatic-safe container.

The following table shows how humidity affects the electrostatic voltage levels generated by different activities.

△ **CAUTION:** A product can be degraded by as little as 700 V.

Typical electrostatic voltage levels			
Event	Relative humidity		
	10%	40%	55%
Walking across carpet	35,000 V	15,000 V	7,500 V
Walking across vinyl floor	12,000 V	5,000 V	3,000 V
Motions of bench worker	6,000 V	800 V	400 V
Removing DIPS from plastic tube	2,000 V	700 V	400 V
Removing DIPS from vinyl tray	11,500 V	4,000 V	2,000 V
Removing DIPS from Styrofoam	14,500 V	5,000 V	3,500 V
Removing bubble pack from PCB	26,500 V	20,000 V	7,000 V
Packing PCBs in foam-lined box	21,000 V	11,000 V	5,000 V

Packaging and transporting guidelines

Follow these grounding guidelines when packaging and transporting equipment:

- To avoid hand contact, transport products in static-safe tubes, bags, or boxes.
- Protect ESD-sensitive parts and assemblies with conductive or approved containers or packaging.
- Keep ESD-sensitive parts in their containers until the parts arrive at static-free workstations.
- Place items on a grounded surface before removing items from their containers.
- Always be properly grounded when touching a component or assembly.
- Store reusable ESD-sensitive parts from assemblies in protective packaging or nonconductive foam.
- Use transporters and conveyors made of antistatic belts and roller bushings. Be sure that mechanized equipment used for moving materials is wired to ground and that proper materials are selected to avoid static charging. When grounding is not possible, use an ionizer to dissipate electric charges.

Workstation guidelines

Follow these grounding workstation guidelines:

- Cover the workstation with approved static-shielding material.
- Use a wrist strap connected to a properly grounded work surface and use properly grounded tools and equipment.
- Use conductive field service tools, such as cutters, screwdrivers, and vacuums.
- When fixtures must directly contact dissipative surfaces, use fixtures made only of static-safe materials.
- Keep the work area free of nonconductive materials, such as ordinary plastic assembly aids and Styrofoam.
- Handle ESD-sensitive components, parts, and assemblies by the case or PCM laminate. Handle these items only at static-free workstations.
- Avoid contact with pins, leads, or circuitry.
- Turn off power and input signals before inserting or removing connectors or test equipment.

Equipment guidelines

Grounding equipment must include either a wrist strap or a foot strap at a grounded workstation.

- When seated, wear a wrist strap connected to a grounded system. Wrist straps are flexible straps with a minimum of one megohm $\pm 10\%$ resistance in the ground cords. To provide proper ground, wear a strap snugly against the skin at all times. On grounded mats with banana-plug connectors, use alligator clips to connect a wrist strap.
- When standing, use foot straps and a grounded floor mat. Foot straps (heel, toe, or boot straps) can be used at standing workstations and are compatible with most types of shoes or boots. On conductive floors or dissipative floor mats, use foot straps on both feet with a minimum of one megohm resistance between the operator and ground. To be effective, the conductive strips must be worn in contact with the skin.

The following grounding equipment is recommended to prevent electrostatic damage:

- Antistatic tape
- Antistatic smocks, aprons, and sleeve protectors
- Conductive bins and other assembly or soldering aids
- Nonconductive foam
- Conductive tabletop workstations with ground cords of one megohm resistance
- Static-dissipative tables or floor mats with hard ties to the ground
- Field service kits
- Static awareness labels
- Material-handling packages
- Nonconductive plastic bags, tubes, or boxes
- Metal tote boxes
- Electrostatic voltage levels and protective materials

The following table lists the shielding protection provided by antistatic bags and floor mats.

Material	Use	Voltage protection level
Antistatic plastic	Bags	1,500 V
Carbon-loaded plastic	Floor mats	7,500 V
Metallized laminate	Floor mats	5,000 V

Unknown user password

If the computer you are servicing has an unknown user password, follow these steps to clear the password.

 **NOTE:** These steps also clear CMOS.

Before disassembling the computer, follow these steps:

1. Shut down the computer. If you are unsure whether the computer is off or in Hibernation, turn the computer on, and then shut it down through the operating system.
2. Disconnect all external devices connected to the computer.
3. Disconnect the power from the computer by first unplugging the power cord from the AC outlet and then unplugging the AC adapter from the computer.
4. Remove the battery (see [Battery on page 53](#)).
5. Remove the RTC battery (see [RTC battery on page 61](#)).
6. Wait approximately 5 minutes.
7. Replace the RTC battery and reassemble the computer.
8. Connect AC power to the computer. Do not reinsert any batteries at this time.
9. Turn on the computer.

All passwords and all CMOS settings have been cleared.

Component replacement procedures

This chapter provides removal and replacement procedures.

There are as many as 86 screws, in 12 different sizes, that must be removed, replaced, or loosened when servicing the computer. Make special note of each screw size and location during removal and replacement.

Serial number

Report the computer serial number to HP when requesting information or ordering spare parts. The serial number is located on the bottom of the computer.

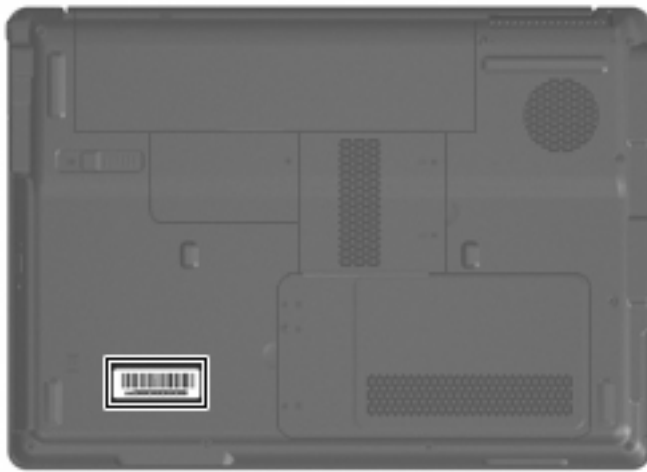

Computer feet

Description	Spare part number
Rubber Feet Kit (includes base enclosure rubber feet and display bezel screw covers)	417096-001

The computer feet are adhesive-backed rubber pads. The feet attach to the base enclosure in the locations illustrated below.

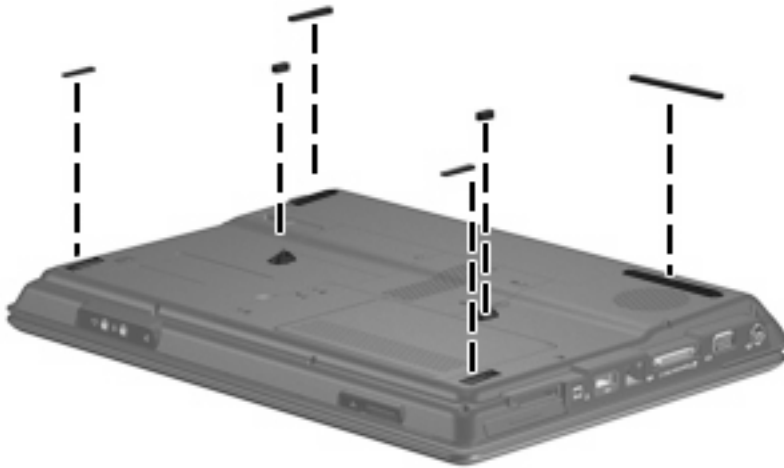

Battery

Description	Spare part number
For use in computer models with Intel or AMD processors:	
6-cell, 2.55-Ah Li-ion battery	441611-001
For use in computer models with Intel processors:	
12-cell, 2.20-Ah Li-ion battery	452056-001
6-cell, 2.20-Ah Li-ion battery	452057-001

Before disassembling the computer, follow these steps:

1. Shut down the computer. If you are unsure whether the computer is off or in Hibernation, turn the computer on, and then shut it down through the operating system.
2. Disconnect all external devices connected to the computer.
3. Disconnect the power from the computer by first unplugging the power cord from the AC outlet and then unplugging the AC adapter from the computer.

Remove the battery:

1. Turn the computer upside down on a flat surface.
2. Slide the battery release latch **(1)** to release the battery.
3. Pivot the battery **(2)** upward and remove it from the computer.



To insert the battery, insert the rear edge of the battery into the battery bay and pivot the front edge downward until the battery is seated. The battery release latch automatically locks the battery into place.

Hard drive

 **NOTE:** All hard drive spare part kits include a hard drive bracket.

Description	Spare part number
For use in computer models with Intel processors:	
320-GB, 5400-rpm	459611-003
250-GB, 5400-rpm	453949-001
200-GB, 4200-rpm	455740-001
160-GB, 5400-rpm	452060-001
120-GB, 5400-rpm	452059-001
80-GB, 5400-rpm	452058-001
For use in computer models with AMD processors:	
320-GB, 5400-rpm	459611-002
250-GB, 5400-rpm	455827-001
160-GB, 5400-rpm	453418-001
120-GB, 5400-rpm	453417-001
80-GB, 5400-rpm	453416-001
Hard drive hardware kit (contains screws, hard drive bracket, and connector; not illustrated)	453419-001

Before removing the hard drive, follow these steps:

1. Shut down the computer. If you are unsure whether the computer is off or in Hibernation, turn the computer on, and then shut it down through the operating system.
2. Disconnect all external devices connected to the computer.
3. Disconnect the power from the computer by first unplugging the power cord from the AC outlet and then unplugging the AC adapter from the computer.
4. Remove the battery (see [Battery on page 53](#)).

Remove the hard drive:

1. Position the computer with the front toward you.
2. Loosen the two Phillips PM2.0×5.0 captive screws **(1)** that secure the hard drive cover to the computer.

3. Lift the left side of the hard drive cover **(2)**, swing it to right, and remove the cover. The hard drive cover is included in the Door/Cover Kit, spare part number 417074-001.

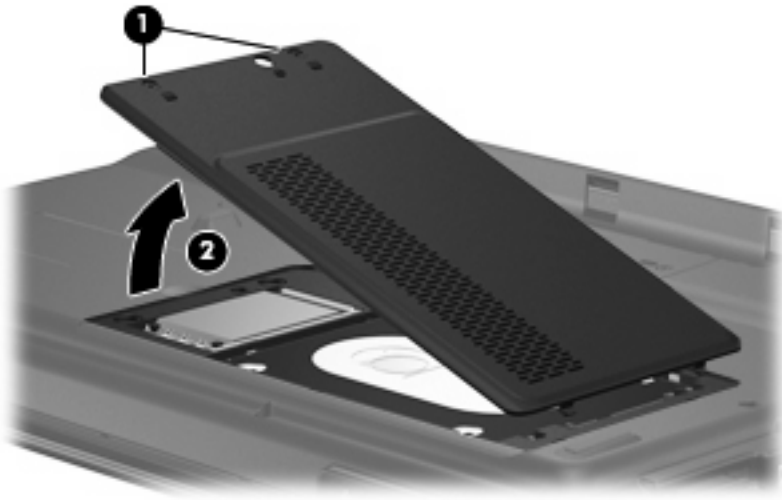

4. Remove the two black Phillips PM2.5×4.0 screws **(1)** that secure the hard drive to the computer.
5. Use the Mylar tab **(2)** to lift the hard drive **(3)** until it disconnects from the computer.

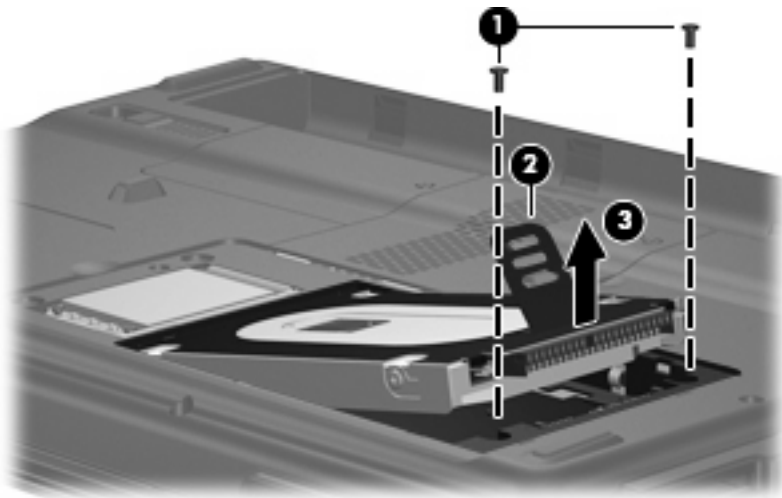

6. Remove the hard drive from the hard drive bay.
7. If it is necessary to replace the hard drive bracket, remove the four Phillips PM3.0×4.0 screws **(1)** that secure the hard drive bracket to the hard drive.

8. Lift the bracket **(2)** straight up to remove it from the hard drive.

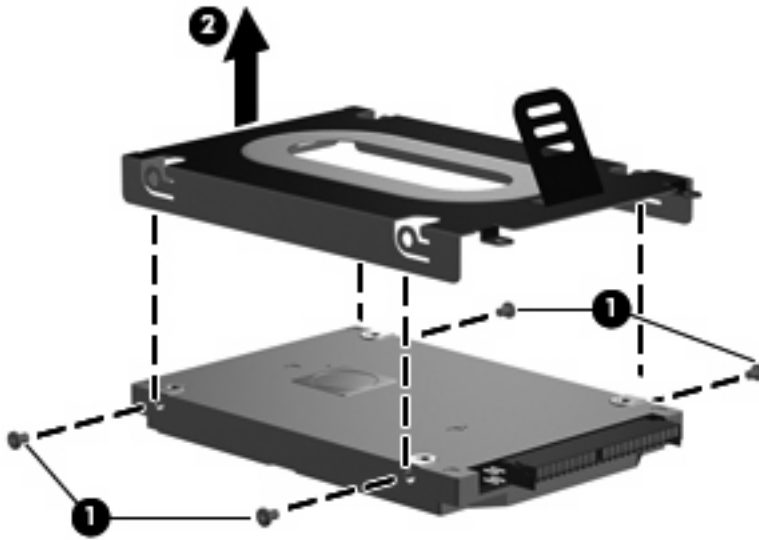

Reverse this procedure to reassemble and install the hard drive.

WLAN module

Description	Spare part number
802.11a/b/g/n WLAN modules:	
For use in Antigua and Barbuda, Argentina, Aruba, the Bahamas, Barbados, Bermuda, Brunei, Canada, the Cayman Islands, Chile, Colombia, Costa Rica, the Dominican Republic, Ecuador, El Salvador, Guam, Guatemala, Haiti, Honduras, Hong Kong, India, Indonesia, Malaysia, Mexico, Panama, Paraguay, Peru, Saudi Arabia, Taiwan, Uruguay, the United States, Venezuela, and Vietnam	441086-001
For use in Austria, Azerbaijan, Bahrain, Belgium, Brazil, Bulgaria, Croatia, Cyprus, the Czech Republic, Denmark, Egypt, Estonia, Finland, France, Georgia, Germany, Greece, Hungary, Iceland, Ireland, Israel, Italy, Latvia, Lebanon, Liechtenstein, Lithuania, Luxembourg, Malta, Monaco, the Netherlands, Norway, Oman, the Philippines, Poland, Portugal, Qatar, Romania, Russia, Serbia and Montenegro, Singapore, Slovakia, Slovenia, South Africa, Spain, Sri Lanka, Sweden, Switzerland, Turkey, Ukraine, the United Kingdom, and Uzbekistan	441086-002
For use in Australia, New Zealand, Pakistan, the People's Republic of China, and South Korea	441086-003
For use in Japan	441086-291
For use in South Korea	441086-AD1
802.11a/b/g WLAN modules:	
For use in Antigua and Barbuda, Argentina, Australia, the Bahamas, Barbados, Brunei, Canada, Chile, the Dominican Republic, Guam, Guatemala, Hong Kong, India, Indonesia, Malaysia, Mexico, New Zealand, Panama, Paraguay, Saudi Arabia, Taiwan, the United States, and Vietnam	452063-001
For use in Aruba, Austria, Azerbaijan, Bahrain, Belgium, Bermuda, Brazil, Bulgaria, the Cayman Islands, Colombia, Croatia, Cyprus, the Czech Republic, Denmark, Egypt, El Salvador, Estonia, Finland, France, Georgia, Germany, Greece, Hungary, Iceland, Ireland, Italy, Jordan, Latvia, Lebanon, Liechtenstein, Lithuania, Luxembourg, Malta, Monaco, the Netherlands, Norway, Oman, the Philippines, Poland, Portugal, Romania, Russia, Serbia and Montenegro, Singapore, Slovakia, Slovenia, South Africa, Spain, Sri Lanka, Sweden, Switzerland, Turkey, the United Kingdom, and Uzbekistan	452063-002
For use in Ecuador, Haiti, Honduras, Pakistan, the People's Republic of China, Peru, Qatar, South Korea, Uruguay, and Venezuela	452063-003
802.11b/g WLAN module for use in Thailand	409407-004
Broadcom 4311AG 802.11a/b/g modules:	
For use in the United States and Canada	441075-001
For use in Afghanistan, Albania, Algeria, Andorra, Angola, Antigua & Barbuda, Argentina, Armenia, Aruba, Australia, Austria, Azerbaijan, the Bahamas, Bahrain, Bangladesh, Barbados, Belarus, Belgium, Belize, Benin, Bermuda, Bhutan, Bolivia, Bosnia & Herzegovina Botswana, Brazil, the British Virgin Islands, Brunei, Bulgaria, Burkina Faso, Burundi, Cambodia, Cameroon, Cape Verde, the Central African Republic, Chad, Chile, Colombia, Comoros, the Congo, Costa Rica, Croatia, Cyprus, the Czech Republic, Denmark, Djibouti, Dominica, the Dominican Republic, East Timor, Ecuador, Egypt, El Salvador, Equatorial Guinea, Eritrea, Estonia, Ethiopia, Fiji, Finland, France, French Guiana, Gabon, Gambia, Georgia, Germany, Ghana, Gibraltar, Greece, Grenada, Guadeloupe, Guatemala, Guinea, Guinea-Bissau, Guyana, Haiti, Honduras, Hong Kong, Hungary, Iceland, India, Indonesia, Ireland, Israel, Italy, the Ivory Coast, Jamaica, Jordan, Kazakhstan, Kenya, Kiribati, Kuwait, Kyrgyzstan, Laos, Latvia, Lebanon, Lesotho, Liberia, Liechtenstein, Lithuania, Luxembourg, Macedonia, Madagascar, Malawi, Malaysia, the Maldives, Mali, Malta, the Marshall Islands, Martinique, Mauritania, Mauritius, Mexico, Micronesia, Monaco, Mongolia, Montenegro, Morocco, Mozambique, Namibia, Nauru, Nepal, the Nether Antilles, the Netherlands, New Zealand, Nicaragua, Niger, Nigeria, Norway, Oman, Palau, Panama, Papua New Guinea, Paraguay, the People's Republic of China, Peru, the Philippines, Poland, Portugal, Qatar, the Republic of Moldova, Romania, Russia, Rwanda, Samoa, San Marino, Sao Tome & Principe, Saudi Arabia, Senegal, Serbia and Montenegro, the Seychelles, Sierra Leone, Singapore, Slovakia, Slovenia, the Solomon Islands, Somalia, South Africa, South Korea, Spain, Sri Lanka, St. Kitts & Nevis, St. Lucia, St. Vincent &	441075-002

Description	Spare part number
Grenadines, Suriname, Swaziland, Sweden, Switzerland, Taiwan, Tajikistan, Tanzania, Thailand, Togo, Tonga, Trinidad & Tobago, Tunisia, Turkey, Turkmenistan, Tuvalu, Uganda, Ukraine, the United Arab Emirates, the United Kingdom, Uruguay, Uzbekistan, Vanuatu, Venezuela, Vietnam, Yemen, Zaire, Zambia, and Zimbabwe	
For use in Japan	441075-291
Broadcom 802.11b/g WLAN modules:	
For use in Canada, the Cayman Islands, Guam, Puerto Rico, the U.S. Virgin Islands, and the United States	441090-001
For use in Afghanistan, Albania, Algeria, Andorra, Angola, Antigua & Barbuda, Argentina, Armenia, Aruba, Australia, Austria, Azerbaijan, the Bahamas, Bahrain, Bangladesh, Barbados, Belarus, Belgium, Belize, Benin, Bermuda, Bhutan, Bolivia, Bosnia & Herzegovina Botswana, Brazil, the British Virgin Islands, Brunei, Bulgaria, Burkina Faso, Burundi, Cambodia, Cameroon, Cape Verde, the Central African Republic, Chad, Chile, Colombia, Comoros, the Congo, Costa Rica, Croatia, Cyprus, the Czech Republic, Denmark, Djibouti, Dominica, the Dominican Republic, East Timor, Ecuador, Egypt, El Salvador, Equatorial Guinea, Eritrea, Estonia, Ethiopia, Fiji, Finland, France, French Guiana, Gabon, Gambia, Georgia, Germany, Ghana, Gibraltar, Greece, Grenada, Guadeloupe, Guatemala, Guinea, Guinea-Bissau, Guyana, Haiti, Honduras, Hong Kong, Hungary, Iceland, India, Indonesia, Ireland, Israel, Italy, the Ivory Coast, Jamaica, Jordan, Kazakhstan, Kenya, Kiribati, Kuwait, Kyrgyzstan, Laos, Latvia, Lebanon, Lesotho, Liberia, Liechtenstein, Lithuania, Luxembourg, Macedonia, Madagascar, Malawi, Malaysia, the Maldives, Mali, Malta, the Marshall Islands, Martinique, Mauritania, Mauritius, Mexico, Micronesia, Monaco, Mongolia, Montenegro, Morocco, Mozambique, Namibia, Nauru, Nepal, the Nether Antilles, the Netherlands, New Zealand, Nicaragua, Niger, Nigeria, Norway, Oman, Palau, Panama, Papua New Guinea, Paraguay, the People's Republic of China, Peru, the Philippines, Poland, Portugal, Qatar, the Republic of Moldova, Romania, Russia, Rwanda, Samoa, San Marino, Sao Tome & Principe, Saudi Arabia, Senegal, Serbia and Montenegro, the Seychelles, Sierra Leone, Singapore, Slovakia, Slovenia, the Solomon Islands, Somalia, South Africa, South Korea, Spain, Sri Lanka, St. Kitts & Nevis, St. Lucia, St. Vincent & Grenadines, Suriname, Swaziland, Sweden, Switzerland, Taiwan, Tajikistan, Tanzania, Thailand, Togo, Tonga, Trinidad & Tobago, Tunisia, Turkey, Turkmenistan, Tuvalu, Uganda, Ukraine, the United Arab Emirates, the United Kingdom, Uruguay, Uzbekistan, Vanuatu, Venezuela, Vietnam, Yemen, Zaire, Zambia, and Zimbabwe	441090-002
For use in Japan	441090-291
802.11n WLAN modules:	
For use in the United States and Canada	436255-001
For use in the Argentina, Australia, Belize, Bolivia, Brazil, Chile, Columbia, Costa Rica, Ecuador, El Salvador, Guatemala, Honduras, Hong Kong, Indonesia, Nicaragua, Paraguay, the People's Republic of China, Peru, South Korea, Taiwan, Thailand, Uruguay, Venezuela	436256-001
For use in Japan	436256-291
Broadcom BCM4312 WLAN b/g modules:	
For use in Canada, Cayman Islands, Guam, Puerto Rico, the United States, and the Virgin Islands	459263-001
For use in Afghanistan, Albania, Algeria, Andorra, Angola, Antigua & Barbuda, Argentina, Armenia, Australia, Austria, Azerbaijan, Bahamas, Bahrain, Bangladesh, Barbados, Belarus, Belgium, Belize, Benin, Bhutan, Bolivia, Bosnia & Herzegovina, Botswana, Brazil, Brunei, Bulgaria, Burkina, Faso Burundi, Cambodia, Cameroon, Cape Verde, Central African Republic, Chad, Chile, People's Republic of China, Colombia, Comoros, Congo, Costa Rica, Croatia, Cyprus, Czech Republic, Zaire, Denmark, Djibouti, Dominica, Dominican Republic, Ecuador, Egypt, El Salvador, Equatorial Guinea, Eritrea, Estonia, Ethiopia, Fiji, Finland, France, Gabon, Gambia, Georgia, Germany, Ghana, Gibraltar, Greece, Grenada, Guatemala, Guinea, Guinea-Bissau, Guyana, Haiti, Honduras, Hong Kong, Hungary, Iceland, India, Indonesia, Ireland, Israel, Italy, Ivory Coast, Jamaica, Japan, Jordan, Kazakhstan, Kenya, Kiribati, Kuwait, Kyrgyzstan, Laos, Latvia, Lebanon, Lesotho, Liberia, Martinique, British Virgin Islands, French Guiana, Guadeloupe, Nether Antilles, Aruba, Bermuda, Syria, Liechtenstein, Lithuania, Luxembourg, Macedonia, Madagascar, Malawi, Malaysia, Maldives, Mali,	459263-002

Description**Spare part number**

Malta, Marshall Islands, Mauritania, Mauritius, Mexico, Micronesia, Monaco, Mongolia, Montenegro, Morocco, Mozambique, Namibia, Nauru, Nepal, Netherlands, New Zealand, Nicaragua, Niger, Nigeria, Norway, Oman, Pakistan, Palau, Panama, Papua New Guinea, Paraguay, Peru, Philippines, Poland, Portugal, Qatar, Republic of Moldova, Romania, Russia, Rwanda, Samoa, San Marino, Sao Tome & Principe, Saudi Arabia, Senegal, Serbia and Montenegro, Seychelles, Sierra Leone, Singapore, Slovakia, Slovenia, Solomon Islands, Somalia, South Africa, South Korea, Spain, Sri Lanka, St. Kitts & Nevis, St. Lucia, St. Vincent & Grenadines, Suriname, Swaziland, Sweden, Switzerland, Taiwan, Tajikistan, Tanzania, Thailand, East Timor, Togo, Tonga, Trinidad & Tobago, Tunisia, Turkey, Turkmenistan, Tuvalu, Uganda, Ukraine, United Arab Emirates, United Kingdom, Uruguay, Uzbekistan, Vanuatu, Venezuela, Vietnam, Yemen, Zambia, and Zimbabwe

Before removing the WLAN module, follow these steps:

1. Shut down the computer. If you are unsure whether the computer is off or in Hibernation, turn the computer on, and then shut it down through the operating system.
2. Disconnect all external devices connected to the computer.
3. Disconnect the power from the computer by first unplugging the power cord from the AC outlet and then unplugging the AC adapter from the computer.
4. Remove the battery (see [Battery on page 53](#)).
5. Remove the hard drive cover (see [Hard drive on page 54](#)).

Remove the WLAN module:

1. Position the computer with the front toward you.
2. Loosen the Phillips PM2.0×5.0 captive screw **(1)** that secures the wireless module compartment cover to the computer.
3. Lift the right edge of the wireless module compartment cover **(2)**, swing it to the left, and remove the cover. The wireless module compartment cover is included in the Door/Cover Kit, spare part number 417074-001.

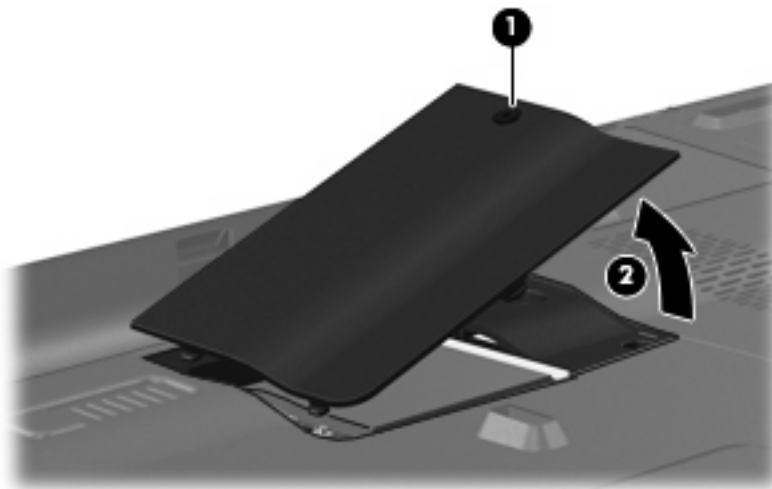

4. Disconnect the two WLAN antenna cables **(1)** from the WLAN module.

 **NOTE:** The black WLAN antenna cable is connected to the WLAN module “Main” terminal. The white WLAN antenna cable is connected to the WLAN module “Aux” terminal.

NOTE: Computer models equipped with an 802.11a/b/g/n WLAN module will have an additional wireless antenna cable **(2)**, yellow in color.

5. Remove the two Phillips PM2.0×3.0 screws **(3)** that secure the WLAN module to the computer. (The edge of the module opposite the slot rises away from the computer.)
6. Remove the WLAN module **(4)** by pulling it away from the slot at an angle.

 **NOTE:** WLAN modules are designed with a notch **(5)** to prevent incorrect installation into the WLAN module slot.

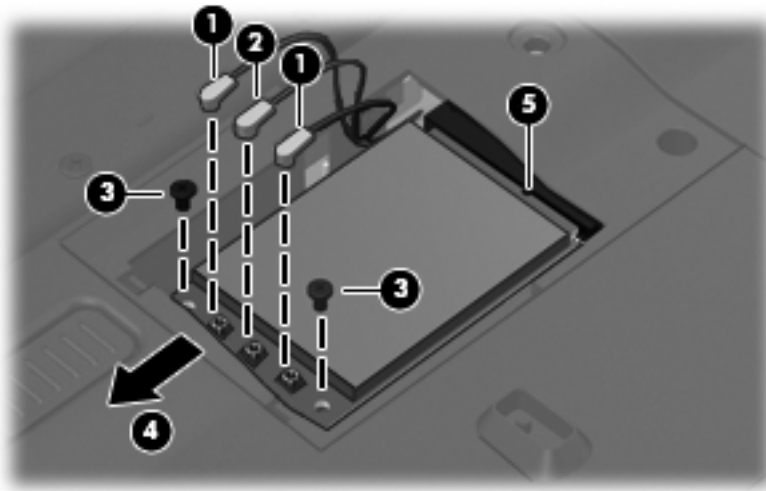

Reverse this procedure to install a WLAN module.

RTC battery

 **NOTE:** Removing the RTC battery and leaving it uninstalled for 5 or more minutes causes all passwords and CMOS settings to be cleared.

Description	Spare part number
RTC battery (includes 2-sided tape)	417076-001

Before removing the RTC battery, follow these steps:

1. Shut down the computer. If you are unsure whether the computer is off or in Hibernation, turn the computer on, and then shut it down through the operating system.
2. Disconnect all external devices connected to the computer.
3. Disconnect the power from the computer by first unplugging the power cord from the AC outlet and then unplugging the AC adapter from the computer.
4. Remove the battery (see [Battery on page 53](#)).
5. Remove the hard drive cover (see [Hard drive on page 54](#)).

Remove the RTC battery:

1. Disconnect the RTC battery cable **(1)** from the system board.
2. Remove the RTC battery **(2)**.

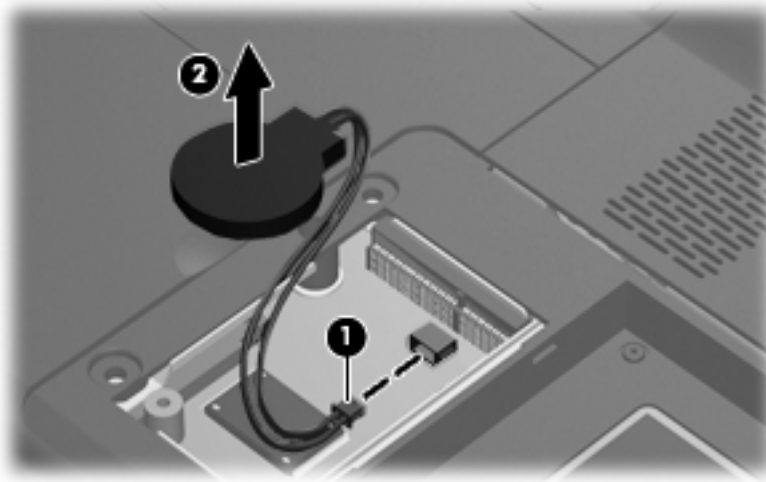

Reverse this procedure to install the RTC battery.

Memory module

Description	Spare part number
For use in computer models with Intel processors:	
2048-MB (667-MHz, PC2-5300, 1-DIMM)	455739-001
1024-MB (667-MHz, PC2-5300, 1-DIMM)	452062-001
512-MB (667-MHz, PC2-5300, 1-DIMM)	452061-001
For use in computer models with AMD processors:	
2048-MB (667-MHz, PC-5300, 1-DIMM)	448151-002
1024-MB (667-MHz, PC2-5300, 1-DIMM)	453415-001
512-MB (667-MHz, PC2-5300, 1-DIMM)	453414-001

Before removing the memory module, follow these steps:

1. Shut down the computer. If you are unsure whether the computer is off or in Hibernation, turn the computer on, and then shut it down through the operating system.
2. Disconnect all external devices connected to the computer.
3. Disconnect the power from the computer by first unplugging the power cord from the AC outlet and then unplugging the AC adapter from the computer.
4. Remove the battery (see [Battery on page 53](#)).

Remove the memory module:

1. Position the computer with the front toward you.
2. Loosen the two Phillips PM2.0×5.0 captive screws **(1)** that secure the memory module compartment cover to the computer.
3. Lift the right side of the cover **(2)**, swing it to the left, and remove the cover. The memory module compartment cover is included in the Door/Cover Kit, spare part number 417074-001.

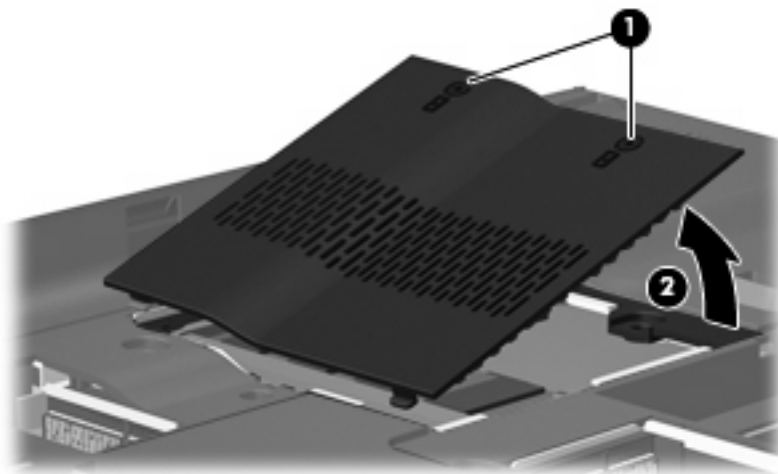

4. Spread the retaining tabs **(1)** on each side of the memory module slot to release the memory module. (The edge of the module opposite the slot rises away from the computer.)
5. Remove the module **(2)** by pulling it away from the slot at an angle.

 **NOTE:** Memory modules are designed with a notch **(3)** to prevent incorrect installation into the memory module slot.

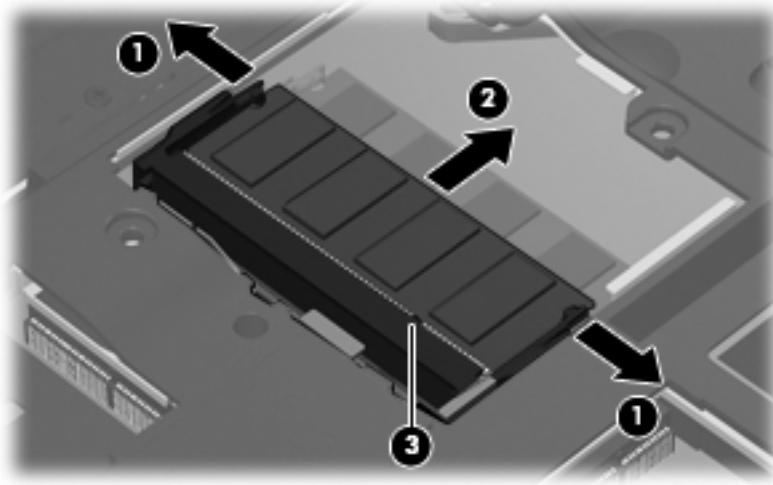

Reverse this procedure to install a memory module.

Optical drive

 **NOTE:** All optical drive spare part kits include an optical drive bezel.

Description	Spare part number
For use in computer models with Intel processors:	
DVD±RW and CD-RW Super Multi Double-Layer Combo Drive with LightScribe	452055-001
DVD±RW and CD-RW Super Multi Double-Layer Combo Drive	452054-001
DVD/CD-RW Combo Drive	452053-001
For use in computer models with AMD processors:	
DVD±RW and CD-RW Super Multi Double-Layer Combo Drive with LightScribe	455830-002
DVD±RW and CD-RW Super Multi Double-Layer Combo Drive	455829-002
DVD/CD-RW Combo Drive	455828-002

Before removing the optical drive, follow these steps:

1. Shut down the computer. If you are unsure whether the computer is off or in Hibernation, turn the computer on, and then shut it down through the operating system.
2. Disconnect all external devices connected to the computer.
3. Disconnect the power from the computer by first unplugging the power cord from the AC outlet and then unplugging the AC adapter from the computer.
4. Remove the battery (see [Battery on page 53](#)).

Remove the optical drive:

1. Position the computer with right side toward you.
2. Remove the Phillips PM2.5×9.0 screw **(1)** that secures the optical drive to the computer.
3. Insert a thin tool, such as a paper clip **(2)**, into the release access. (The optical drive media tray is partially ejected from the optical drive.)

4. Use the media tray frame to remove the optical drive **(3)**.

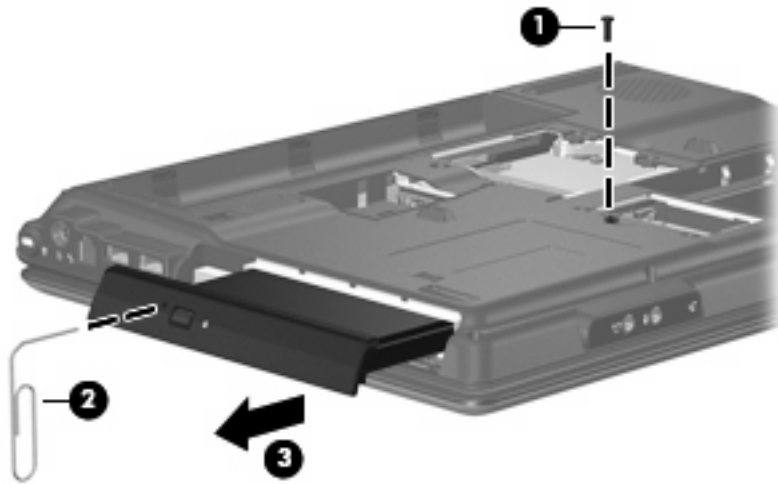

5. If it is necessary to replace the optical drive bracket, position the optical drive with the optical drive bracket toward you.
6. Remove the two Phillips PM2.0x3.0 screws **(1)** that secure the optical drive bracket to the optical drive.
7. Remove the optical drive bracket **(2)**.

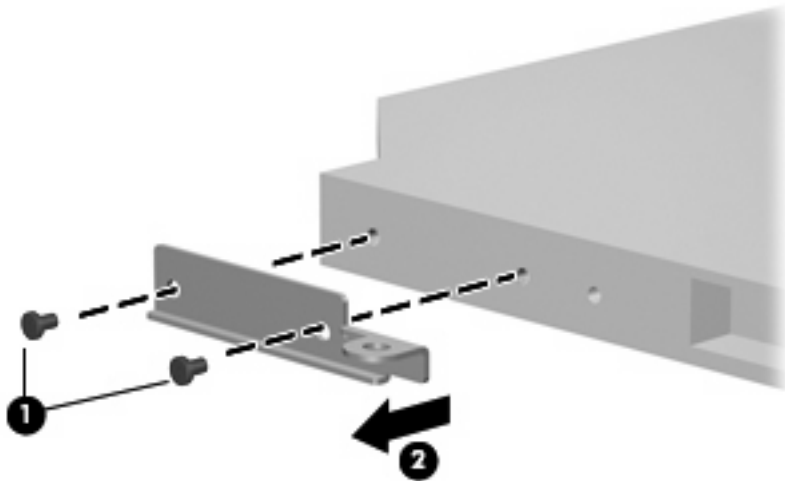

Reverse the above procedure to reassemble and install the optical drive.

Keyboard

For use in:	Spare part number	For use in:	Spare part number
Belgium	448615-021	Portugal	448615-131
Brazil	448615-201	Russia	448615-251
Canadian French	448615-121	Saudi Arabia	448615-171
Denmark, Finland, Norway, and Sweden	448615-DH1	South Korea	448615-AD1
France	448615-051	Spain	448615-071
Germany	448615-041	Switzerland	448615-111
Greece	448615-DJ1	Taiwan	448615-AB1
Israel	448615-BB1	Thailand	448615-281
Italy	448615-061	Turkey	448615-141
Latin America	448615-161	The United Kingdom	448615-031
The Netherlands and Europe	448615-B31	The United States	448615-001

Before removing the keyboard, follow these steps:

1. Shut down the computer. If you are unsure whether the computer is off or in Hibernation, turn the computer on, and then shut it down through the operating system.
2. Disconnect all external devices connected to the computer.
3. Disconnect the power from the computer by first unplugging the power cord from the AC outlet and then unplugging the AC adapter from the computer.
4. Remove the battery (see [Battery on page 53](#)).

Remove the keyboard:

1. Turn the computer upside down, with the front toward you.

2. Remove the three Phillips PM2.5×7.0 screws that secure the keyboard to the computer.

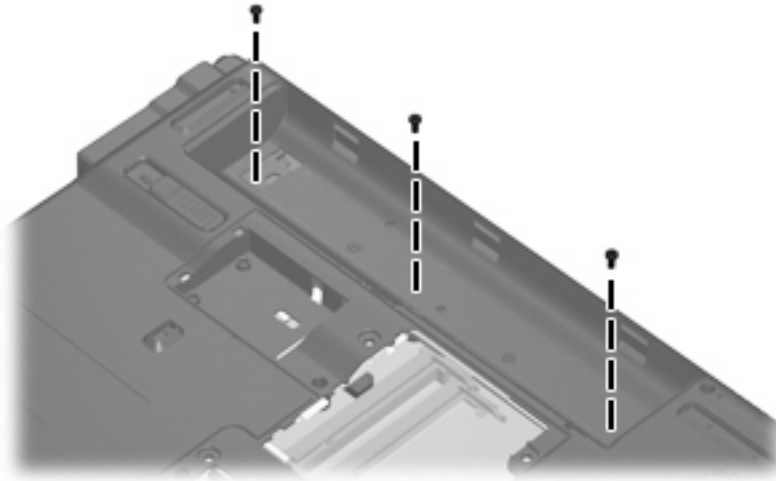

3. Turn the computer display-side up, with the front toward you.
4. Open the computer as far as possible.
5. Lift the rear edge of the keyboard **(1)** until it rests at an angle.
6. Release the keyboard **(2)** by sliding it back to disengage the tabs on the front edge of the keyboard from the top cover.
7. Swing the rear edge of the keyboard **(3)** up and forward until it rests on the palm rest.



8. Release the zero insertion force (ZIF) connector **(1)** to which the keyboard cable is attached and disconnect the keyboard cable **(2)** from the system board.

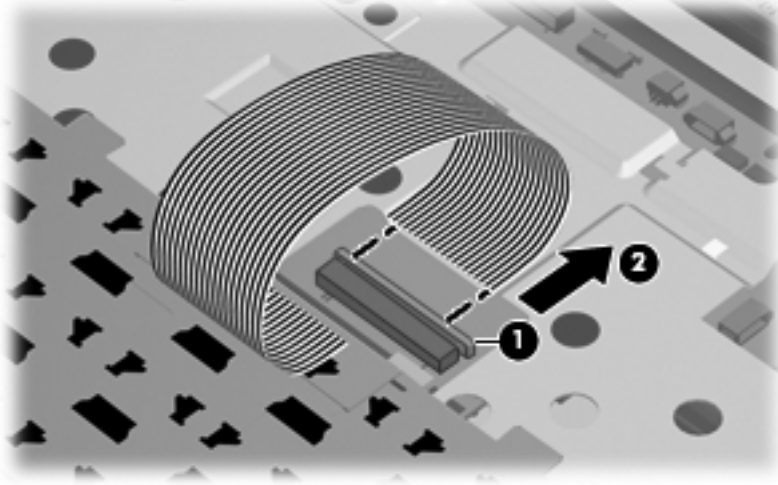

9. Remove the keyboard.

Reverse this procedure to install the keyboard.

Switch cover

Description	Spare part number
Switch cover (includes power button board and cable, LED board, and LED board cable)	
For use in computer models with Intel processors or full-featured models with AMD processors	451313-001
For use in defeatured computer models with AMD processors	417078-001

Before removing the switch cover, follow these steps:

1. Shut down the computer. If you are unsure whether the computer is off or in Hibernation, turn the computer on, and then shut it down through the operating system.
2. Disconnect all external devices connected to the computer.
3. Disconnect the power from the computer by first unplugging the power cord from the AC outlet and then unplugging the AC adapter from the computer.
4. Remove the battery (see [Battery on page 53](#)).
5. Remove the keyboard (see [Keyboard on page 66](#)).

Remove the switch cover:

1. Remove the two Phillips PM2.5×9.0 screws **(1)** and the three black Phillips PM2.0×5.0 screws **(2)** that secure the switch cover to the computer.

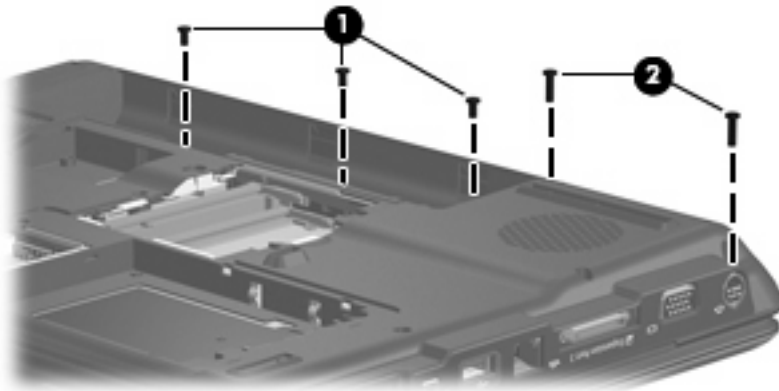

2. Turn the computer display-side up, with the front toward you.
3. Open the computer as far as possible.
4. Disconnect the power button board cable **(1)** from the system board.

5. Release the ZIF connector to which the LED board cable **(2)** is connected and disconnect the cable from the system board.

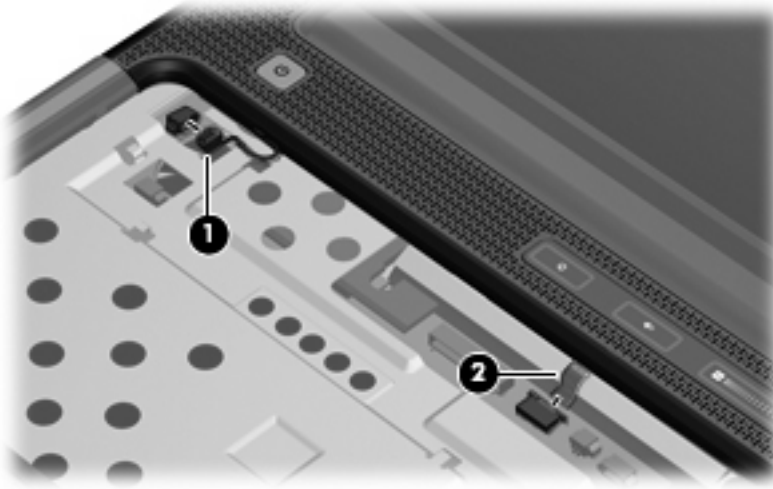

6. Lift the front edge of the switch cover **(1)** to disengage it from the computer.
7. Remove the switch cover **(2)**.

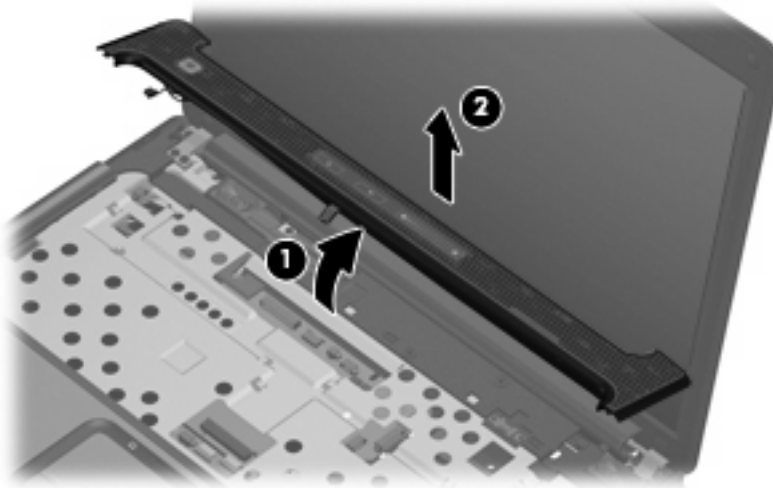

Reverse this procedure to install the switch cover.

Display assembly

Description	Spare part number
14.1-inch, WXGA, BrightView display assembly for use in computer models with Intel or AMD processors without a camera module (includes microphones)	448611-001
14.1-inch, WXGA, BrightView display assembly for use only in defeatured computer models with AMD processors without a camera module	451163-001
14.1-inch, WXGA, BrightView display assembly for use in computer models with Intel or AMD processors without a camera module (includes microphones)	457348-001
14.1-inch, WXGA, BrightView display assembly for use in computer models with Intel or AMD processors without a camera module (does not include microphones)	457349-001
14.1-inch, WXGA, BrightView display assembly for use in computer models with Intel or AMD processors with a camera module (includes microphones)	462761-001

Before removing the display assembly, follow these steps:

1. Shut down the computer. If you are unsure whether the computer is off or in Hibernation, turn the computer on, and then shut it down through the operating system.
2. Disconnect all external devices connected to the computer.
3. Disconnect the power from the computer by first unplugging the power cord from the AC outlet and then unplugging the AC adapter from the computer.
4. Remove the battery (see [Battery on page 53](#)).
5. Disconnect the wireless antenna cables from the WLAN module (see [WLAN module on page 57](#)).
6. Remove the following components:
 - a. Keyboard (see [Keyboard on page 66](#))
 - b. Switch cover (see [Switch cover on page 69](#))

Remove the display assembly:

1. Close the computer and turn it upside down, with the front toward you.

2. Remove the Phillips PM2.5×9.0 screw that secures the display assembly to the computer.

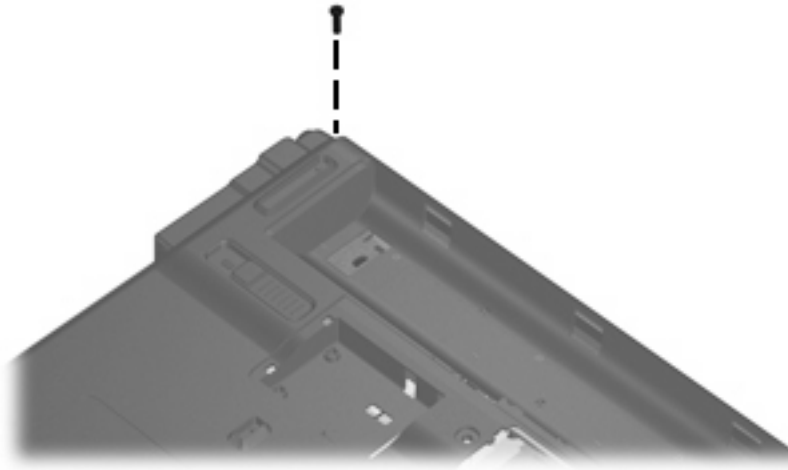

3. Turn the computer display-side up, with the front toward you.
4. Open the display as far as possible.
5. Disconnect the following cables:
 - (1) Display panel cable
 - (2) Display switch module cable
 - (3) Microphone cable
6. Remove the wireless antenna cables (4) from the hole in the system board and the routing channels (5) built into the top cover.

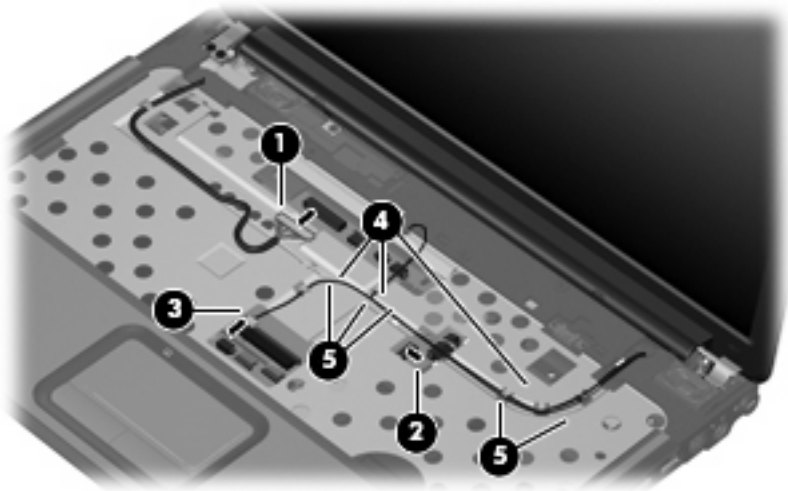

△ **CAUTION:** Support the display assembly when removing the following screws. Failure to support the display assembly can result in damage to the display assembly and other computer components.

7. Remove the five black Phillips PM2.5×7.0 screws (1) that secure the display assembly to the computer.

8. Remove the display assembly **(2)**.

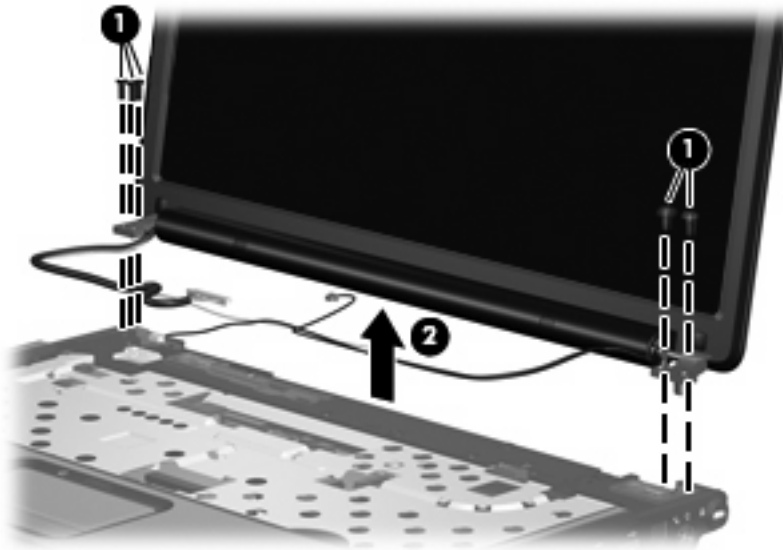

9. If it is necessary to replace any of the display assembly internal components, remove the following screw covers and screws. The display rubber screw covers are included in the Rubber Feet Kit, spare part number 417096-001.

- (1)** Six rubber screw covers on the display bezel top edge and bottom edge corners
- (2)** Two rubber screw covers on the display bezel bottom edge
- (3)** Eight Phillips PM2.5×7.0 screws

 **NOTE:** There are two different sizes of display bezel rubber screw covers. The thicker covers **(2)** must be installed in the bottom center screw holes.

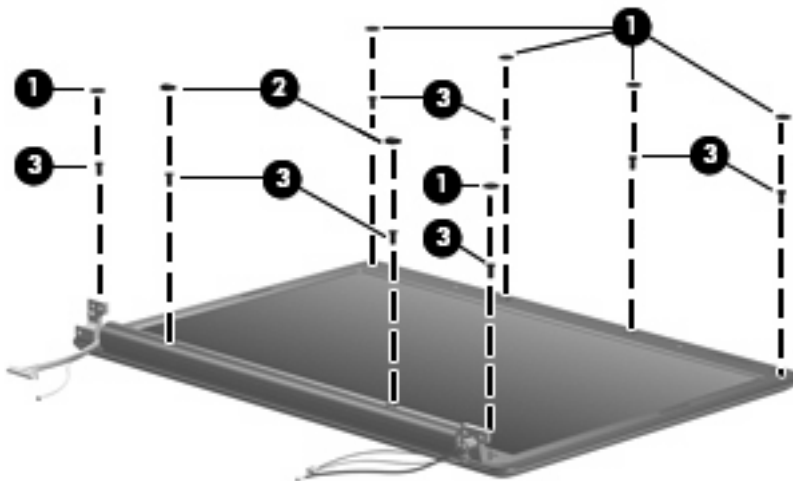

10. Flex the inside edges of the left and right sides **(1)** and the top and bottom sides **(2)** of the display bezel until the bezel disengages from the display enclosure.

11. Remove the display bezel **(3)**. The display bezel is available using spare part number 448613-001 including microphone for computers with Intel or AMD processors without a camera module, 461913-001 for computers including microphone with AMD processors with a camera module, or 455820-001 not including microphone for computers with AMD processors.

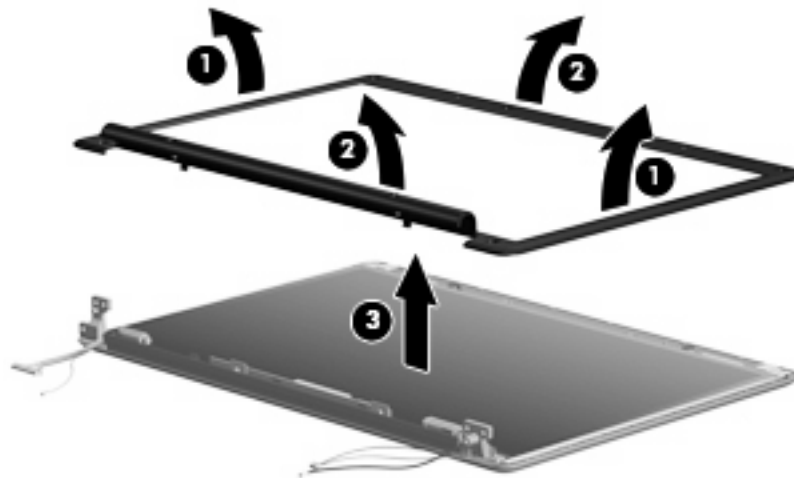

12. If it is necessary to replace the display inverter, remove the two black Phillips PM2.5×5.0 screws **(1)** that secure the inverter to the display enclosure.
13. Release the inverter **(2)** as far as the display panel cable and the backlight cable will allow.
14. Disconnect the display panel cable **(3)** and the backlight cable **(4)** from the display inverter. The display inverter is available using spare part number 417097-001 for computers with Intel processors, 455821-001 for computers with AMD processors.

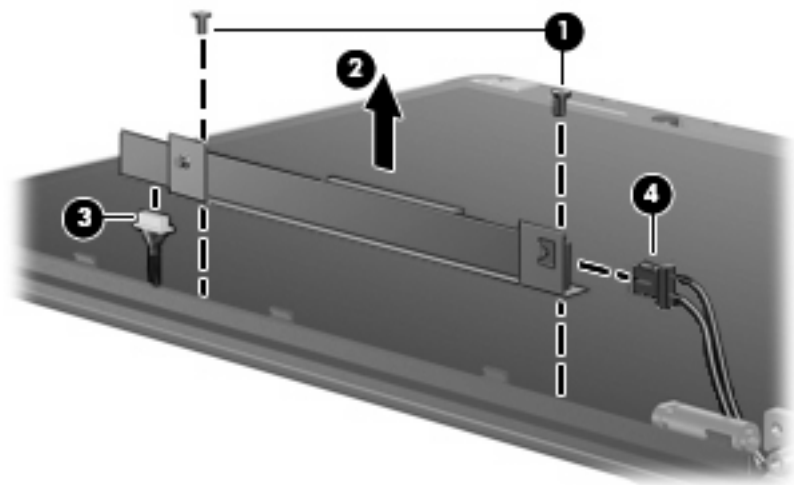

15. Remove the inverter and inverter bracket.
16. Remove the black Phillips PM2.5×5.0 screw **(1)** that secures the inverter to the inverter bracket.

17. Remove the inverter (2) from the bracket.

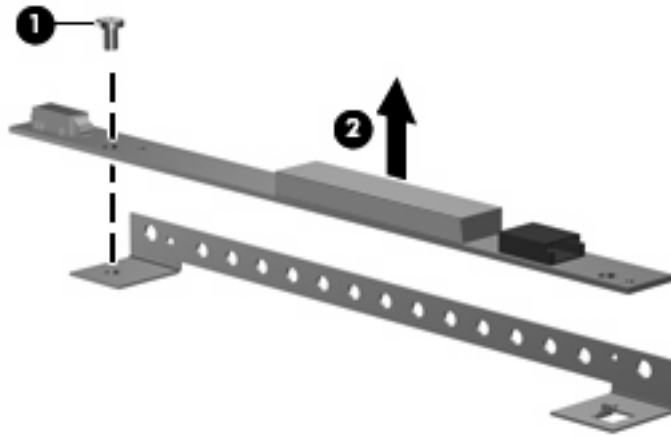

18. If it is necessary to replace the display hinges, remove the two black Phillips PM2.5×5.0 screws (1) that secure each hinge to the display enclosure.
19. Remove the display hinges (2) from the display enclosure. The display hinges are available using spare part number 417103-001 for computers with Intel processors, 455822-001 for computers with AMD processors.

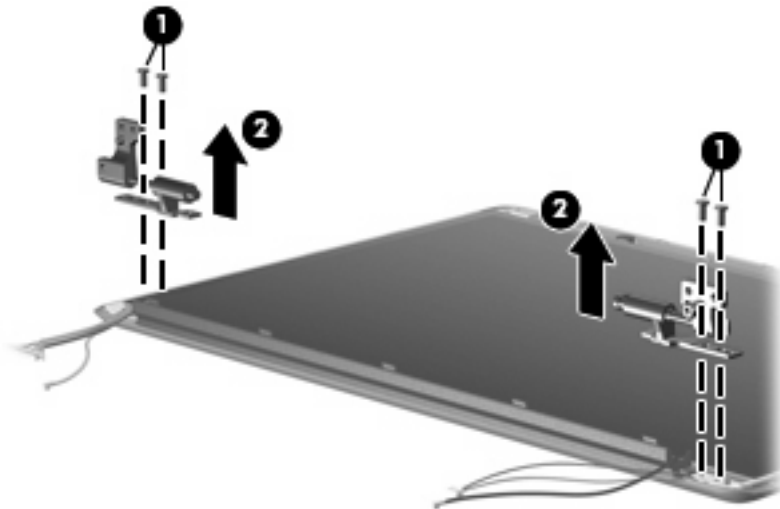

20. If it is necessary to replace the display switch module, remove the black Phillips PM2.5×5.0 screw (1) that secures the display switch module to the display enclosure.

21. Remove the display switch module **(2)**. The display switch module is included in the Display Hinge Kit, spare part number 417103-001 for computers with Intel processors, 455822-001 for computers with AMD processors.

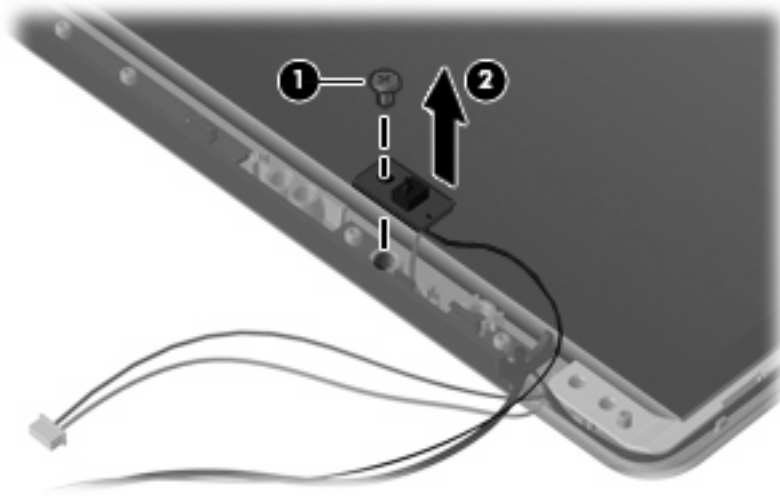

22. If it is necessary to replace the display panel, remove the display panel from the display enclosure. The display panel is available using the spare part number 448602-001 for computers with Intel processors, 455810-001 for computers with AMD processors.

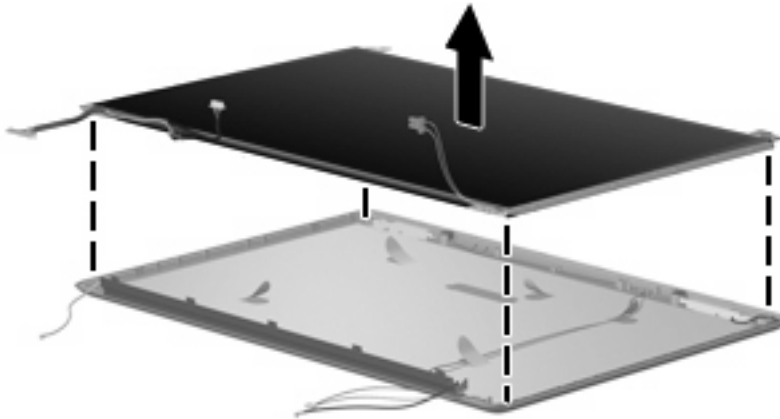

23. If it is necessary to replace the wireless antenna transceivers and cables, remove the Phillips PM2.5×4.0 screw **(1)** that secures each transceiver to the display enclosure.
24. Remove the wireless antenna cables from the clips **(2)** built into the display enclosure.
25. Detach the wireless antenna transceivers **(3)** from the display enclosure.

26. Remove the wireless antenna transceivers and cables **(4)** from the display enclosure. The wireless antenna transceivers and cables are included in the Wireless Antenna Kit, spare part number 417107-001.

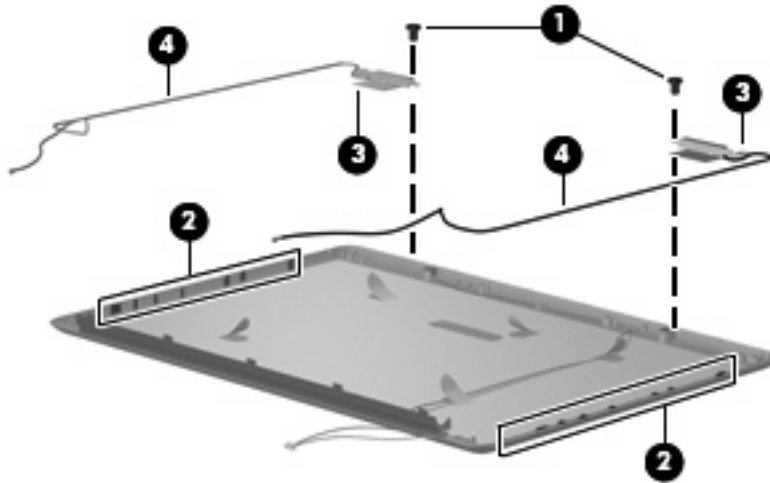

27. If it is necessary to replace the microphone receivers and cables, release the retention tabs **(1)** built into the display enclosure that secure the microphone cables to the display enclosure.
28. Remove the microphone receivers **(2)** from the clips in the display enclosure.
29. Remove the microphone cables **(3)** from the display enclosure. The microphone receivers and cables are included in the Display Cable Kit, spare part number 448614-001 for computers with Intel processors, 458656-001 for computers with AMD processors.

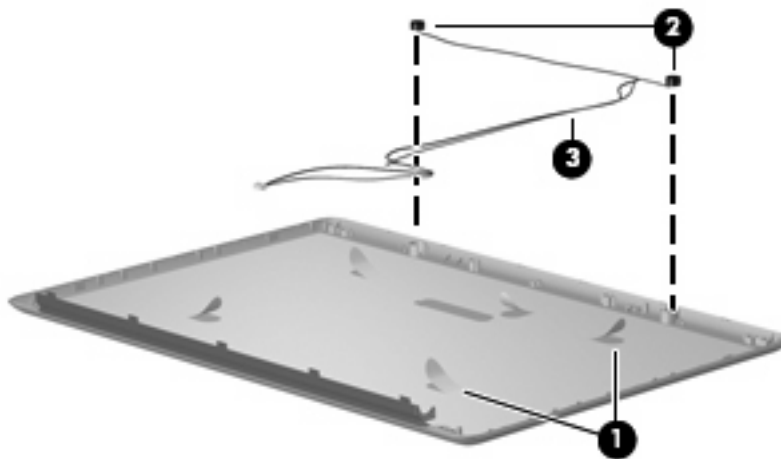

Reverse this procedure to reassemble and install the display assembly.

Camera module

If it has been determined that the camera module is the component that must be replaced to complete the computer repair, the display assembly does not have to be removed. Follow the procedures in this section to replace the camera module. For information on replacing the display assembly and other display assembly internal components, see [Display assembly on page 71](#).

Description	Spare part number
Camera module (includes camera module bracket and 2-sided tape)	453673-001

Before removing the camera module, follow these steps:

1. Shut down the computer. If you are unsure whether the computer is off or in Hibernation, turn the computer on, and then shut it down through the operating system.
2. Disconnect all external devices connected to the computer.
3. Disconnect the power from the computer by first unplugging the power cord from the AC outlet and then unplugging the AC adapter from the computer.
4. Remove the battery (see [Battery on page 53](#)).

Remove the camera module:

1. Turn the computer display-side up, with the front toward you.
2. Open the computer as far as it will open.
3. Remove the four rubber screw covers **(1)** on the display bezel top edge. The display rubber screw covers are included in the Rubber Feet Kit, spare part number 417096-001.
4. Remove the four Phillips PM2.5×7.0 screws **(2)** that secure the display bezel top edge to the display assembly.

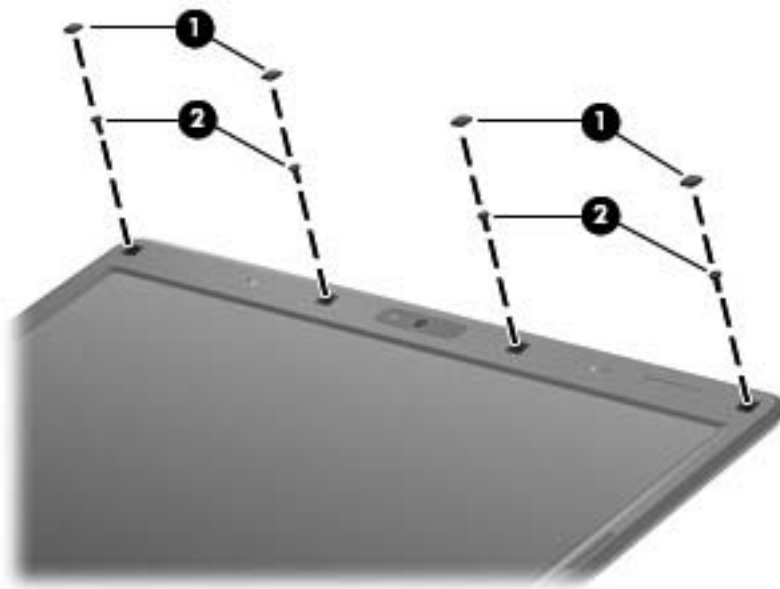

5. Flex the inside edges of the left and right sides **(1)** and the top edge **(2)** of the display bezel until the bezel disengages from the display enclosure.

6. Release the display bezel top edge **(3)**. Display bezels are available using the following spare part numbers:
- 448613-001 (for use with computer models with AMD processors with a camera module; includes microphone; includes openings for camera module and microphones)
 - 462525-001 (for use only with full-featured computer models with Intel processors; includes openings for microphones)
 - 457351-001 (for use only with defeatured computer models with Intel processors; includes openings for microphones)



7. Release the camera module assembly **(1)** from the display enclosure as far as the camera module cable allows.
8. Disconnect the camera module cable **(2)** from the camera module.

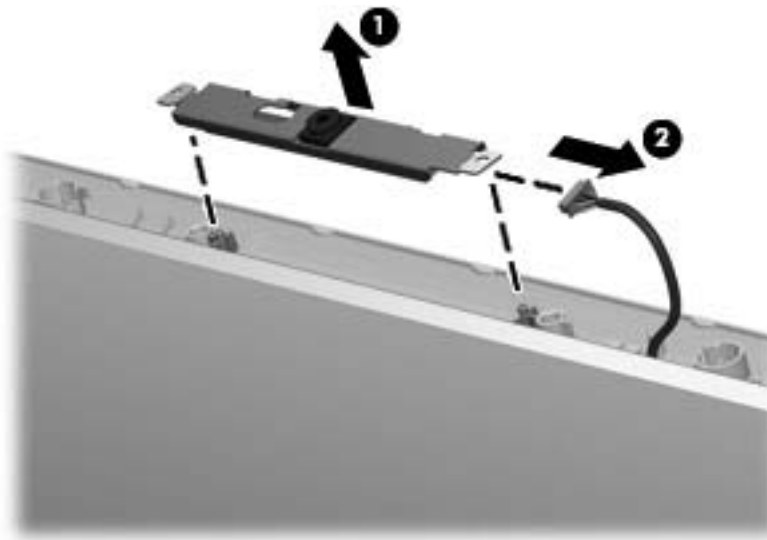

9. Turn the camera module assembly upside down.

10. Remove the two Phillips PM2.0×3.0 screws **(1)** that secure the camera module to the camera module bracket.
11. Remove the camera module **(2)** from the bracket.

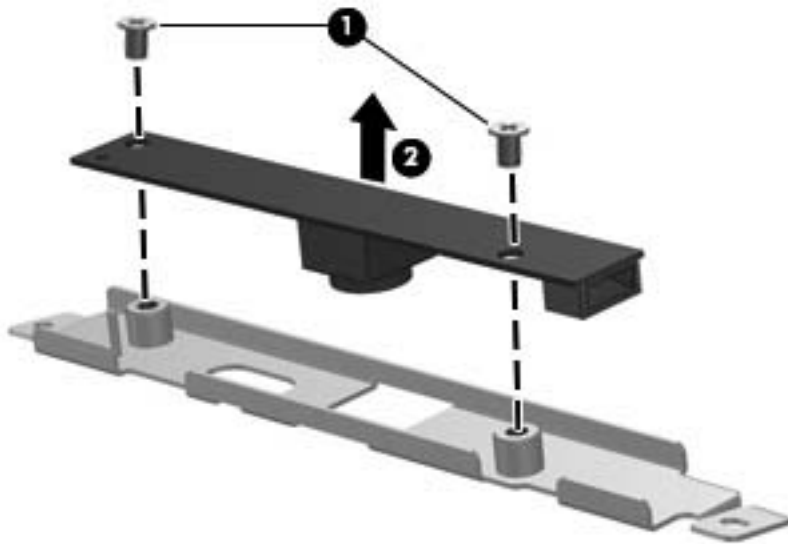

Reverse this procedure to install the camera module.

Top cover

Description	Spare part number
Top cover (includes TouchPad and cable)	
For use only in full-featured computer models with Intel processors and a camera module	462524-001
For use in full-featured computer models with Intel processors without a camera module	448620-001
For use in full-featured computer models with AMD processors	455857-001
For use in defeatured computer models with AMD processors	417091-001
For use only in defeatured computer models with Intel processors	460947-001
For use only in defeatured computer models with Intel processors and a card reader	461267-001

Before removing the top cover, follow these steps:

1. Shut down the computer. If you are unsure whether the computer is off or in Hibernation, turn the computer on, and then shut it down through the operating system.
2. Disconnect all external devices connected to the computer.
3. Disconnect the power from the computer by first unplugging the power cord from the AC outlet and then unplugging the AC adapter from the computer.

4. Remove the battery (see [Battery on page 53](#)).
5. Remove the following components:
 - a. Hard drive (see [Hard drive on page 54](#))
 - b. WLAN cover (see [WLAN module on page 57](#))
 - c. Optical drive (see [Optical drive on page 64](#))
 - d. Keyboard (see [Keyboard on page 66](#))
 - e. Switch cover (see [Switch cover on page 69](#))
 - f. Display assembly (see [Display assembly on page 71](#))

Remove the top cover:

1. Turn the computer upside down, with the front toward you.
2. Remove the seven Phillips PM2.5×9.0 screws that secure the top cover to the computer.

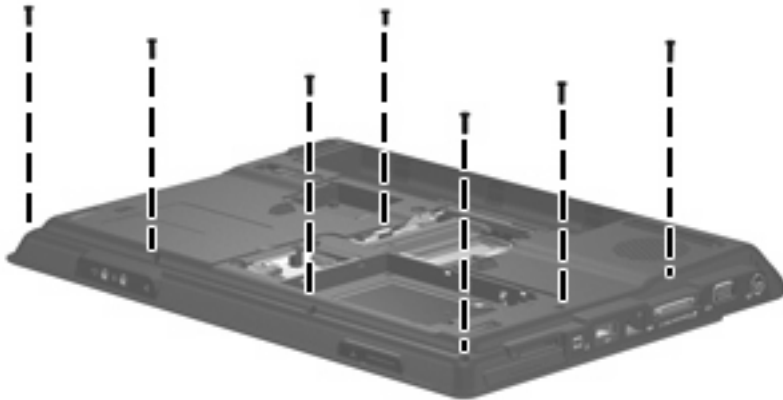

3. Remove the two Phillips PM2.0×3.0 screws **(1)** and the three Phillips PM2.0×5.0 screws **(2)** that secure the top cover to the computer.

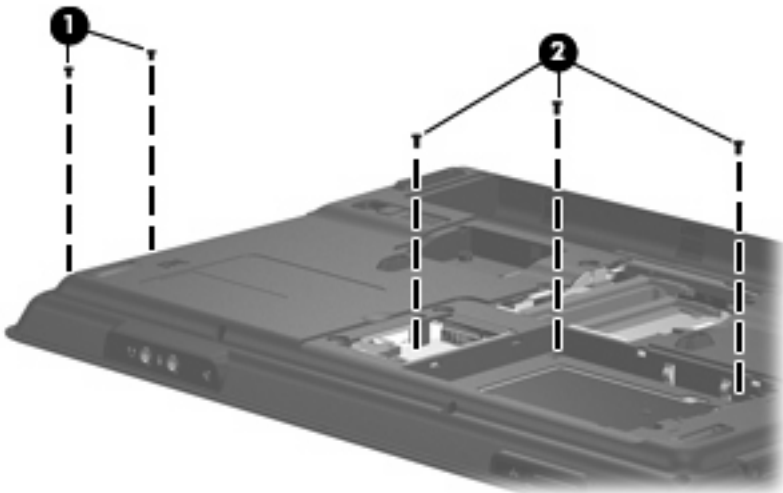

4. Turn the computer right-side up, with the front toward you.

5. Release the ZIF connector **(1)** to which the TouchPad cable is connected and disconnect the cable **(2)** from on the system board.

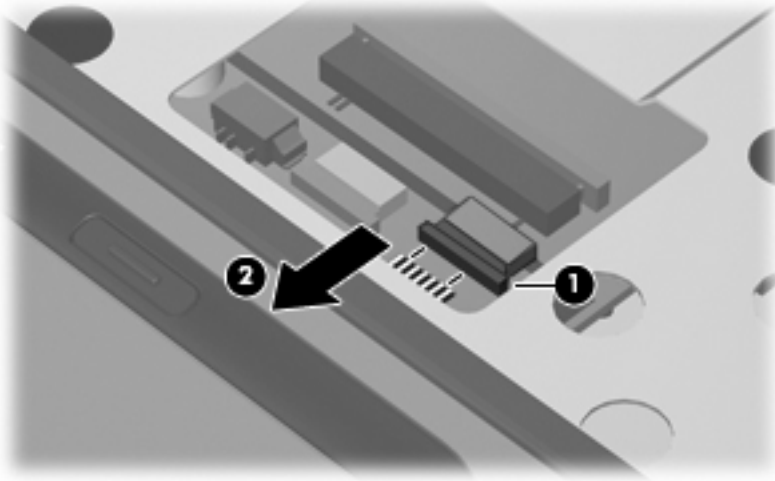

6. Remove the Phillips PM2.5x9.0 screw that secures the top cover to the computer.

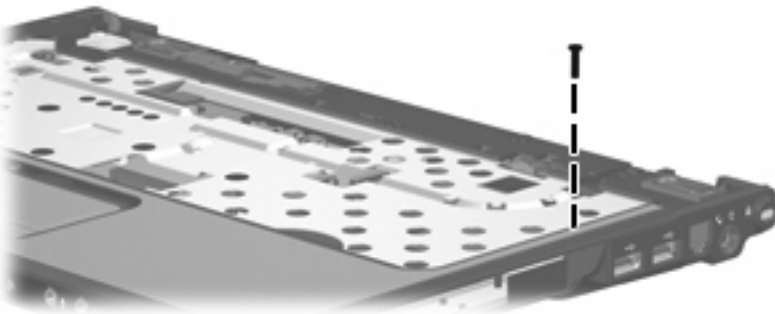

7. Lift the front edge of the top cover and remove it.



Reverse this procedure to install the top cover.

TouchPad

Description	Spare part number
TouchPad for use only in computer models with Intel processors (includes TouchPad bracket and TouchPad cable)	451341-001
TouchPad for use only in computer models with AMD processors (includes TouchPad bracket and TouchPad cable)	455858-001

Before removing the TouchPad, follow these steps:

1. Shut down the computer. If you are unsure whether the computer is off or in Hibernation, turn the computer on, and then shut it down through the operating system.
2. Disconnect all external devices connected to the computer.
3. Disconnect the power from the computer by first unplugging the power cord from the AC outlet and then unplugging the AC adapter from the computer.
4. Remove the battery (see [Battery on page 53](#)).
5. Remove the following components:
 - a. Hard drive (see [Hard drive on page 54](#))
 - b. WLAN cover (see [WLAN module on page 57](#))
 - c. Optical drive (see [Optical drive on page 64](#))
 - d. Keyboard (see [Keyboard on page 66](#))
 - e. Switch cover (see [Switch cover on page 69](#))
 - f. Display assembly (see [Display assembly on page 71](#))
 - g. Top cover (see [Top cover on page 80](#))

Remove the TouchPad:

1. Turn the top cover upside down, with the front toward you.
2. Remove the five Phillips PM2.0×3.0 screws (**1**) that secure the TouchPad assembly to the top cover.

3. Remove the TouchPad bracket **(2)** and TouchPad board **(3)** from the top cover.

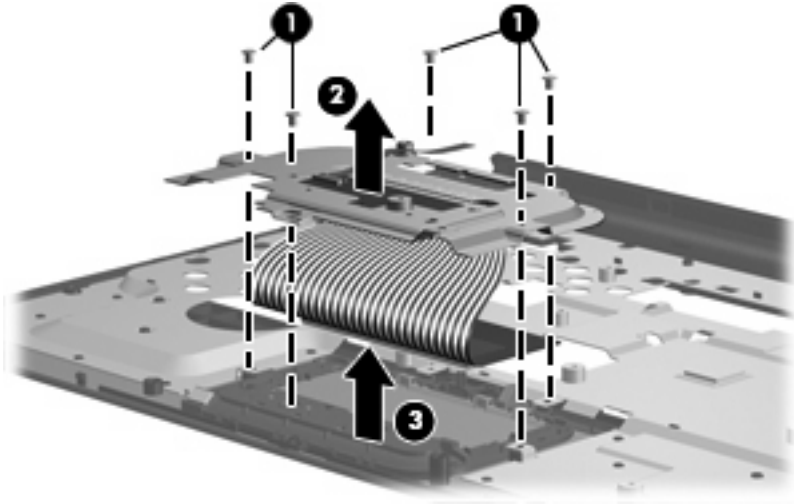

4. Remove the two Phillips PM2.0x2.0 screws **(1)** that secure the TouchPad board to the TouchPad bracket.
5. Remove the TouchPad board **(2)** from the TouchPad bracket.

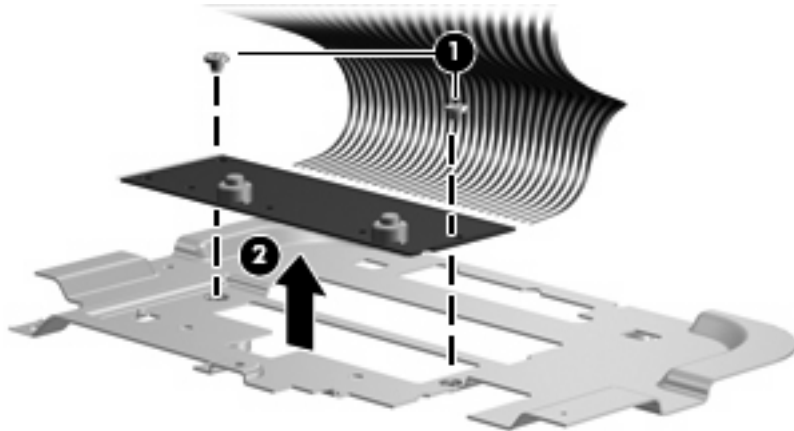

Reverse the above procedure to reassemble and install the TouchPad.

Wireless switch board

Description	Spare part number
Wireless switch board (includes wireless switch board cable)	417092-001

Before removing the wireless switch board, follow these steps:

1. Shut down the computer. If you are unsure whether the computer is off or in Hibernation, turn the computer on, and then shut it down through the operating system.
2. Disconnect all external devices connected to the computer.
3. Disconnect the power from the computer by first unplugging the power cord from the AC outlet and then unplugging the AC adapter from the computer.
4. Remove the battery (see [Battery on page 53](#)).
5. Remove the following components:
 - a. Hard drive (see [Hard drive on page 54](#))
 - b. WLAN cover (see [WLAN module on page 57](#))
 - c. Optical drive (see [Optical drive on page 64](#))
 - d. Keyboard (see [Keyboard on page 66](#))
 - e. Switch cover (see [Switch cover on page 69](#))
 - f. Display assembly (see [Display assembly on page 71](#))
 - g. Top cover (see [Top cover on page 80](#))

Remove the wireless switch board:

1. Disconnect the wireless switch board cable **(1)** from the system board.
2. Remove the two Phillips PM2.0×3.0 screws **(2)** that secure the wireless switch board to the computer.

3. Remove the wireless switch board **(3)**.

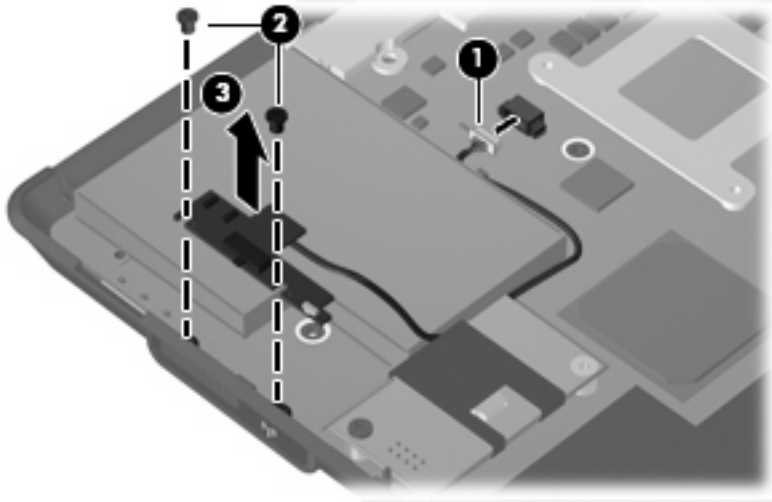

Reverse the above procedure to install the wireless switch board.

Modem module

Description	Spare part number
Modem module (includes modem module cable)	463971-001
Modem module cable	455847-001

Before removing the modem module, follow these steps:

1. Shut down the computer. If you are unsure whether the computer is off or in Hibernation, turn the computer on, and then shut it down through the operating system.
2. Disconnect all external devices connected to the computer.
3. Disconnect the power from the computer by first unplugging the power cord from the AC outlet and then unplugging the AC adapter from the computer.
4. Remove the battery (see [Battery on page 53](#)).
5. Remove the following components:
 - a. Hard drive (see [Hard drive on page 54](#))
 - b. WLAN cover (see [WLAN module on page 57](#))
 - c. Optical drive (see [Optical drive on page 64](#))
 - d. Keyboard (see [Keyboard on page 66](#))
 - e. Switch cover (see [Switch cover on page 69](#))
 - f. Display assembly (see [Display assembly on page 71](#))
 - g. Top cover (see [Top cover on page 80](#))

Remove the modem module:

1. Disconnect the modem module cable **(1)** from the modem module.
2. Remove the Phillips PM2.0×5.0 screw **(2)** that secures the modem module to the system board.

3. Lift up on the front of the modem module (**3**) to disconnect it from the system board.

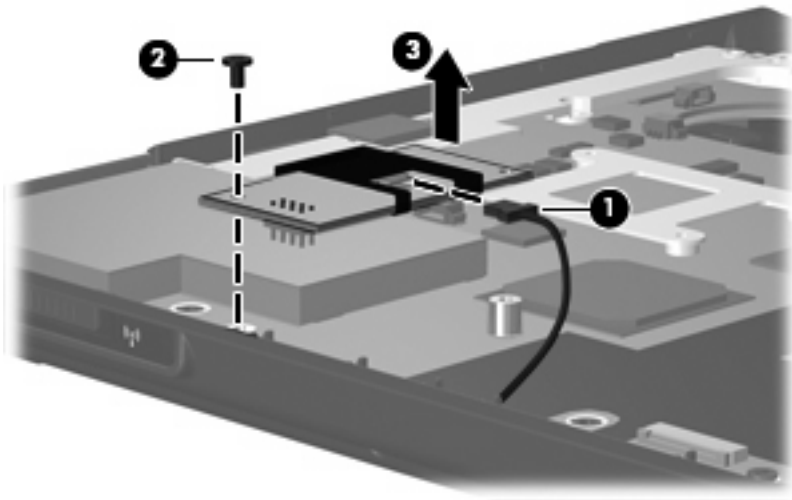

4. Remove the modem module.

Reverse the above procedure to install the modem module.

Audio board

Description	Spare part number
Audio board for use only in full-featured computer models without a camera module (includes audio connectors, infrared lens, and audio board cable)	448627-001
Audio board for use only in defeatured computer models with AMD processors and without a camera module (includes audio connectors, infrared lens, and audio board cable)	459157-001
Audio board for use only in full-featured computer models with a camera module (includes audio connectors, infrared lens, and audio board cable)	463974-001
Audio board for use only in defeatured computer models with AMD processors and with a camera module (includes audio connectors, infrared lens, and audio board cable)	463975-001

Before removing the audio board, follow these steps:

1. Shut down the computer. If you are unsure whether the computer is off or in Hibernation, turn the computer on, and then shut it down through the operating system.
2. Disconnect all external devices connected to the computer.
3. Disconnect the power from the computer by first unplugging the power cord from the AC outlet and then unplugging the AC adapter from the computer.
4. Remove the battery (see [Battery on page 53](#)).
5. Remove the following components:
 - a. Hard drive (see [Hard drive on page 54](#))
 - b. WLAN cover (see [WLAN module on page 57](#))
 - c. Optical drive (see [Optical drive on page 64](#))

- d. Keyboard (see [Keyboard on page 66](#))
- e. Switch cover (see [Switch cover on page 69](#))
- f. Display assembly (see [Display assembly on page 71](#))
- g. Top cover (see [Top cover on page 80](#))

Remove the audio board:

1. Release the ZIF connector to which the audio board cable is connected and disconnect the cable **(1)** from the system board.
2. Remove the Phillips PM2.5×5.0 screw **(2)** that secures the audio board to the computer.
3. Lift the rear edge of the audio board **(3)** and swing it forward until the audio connectors disengage from the base enclosure.
4. Remove the audio board **(4)**.

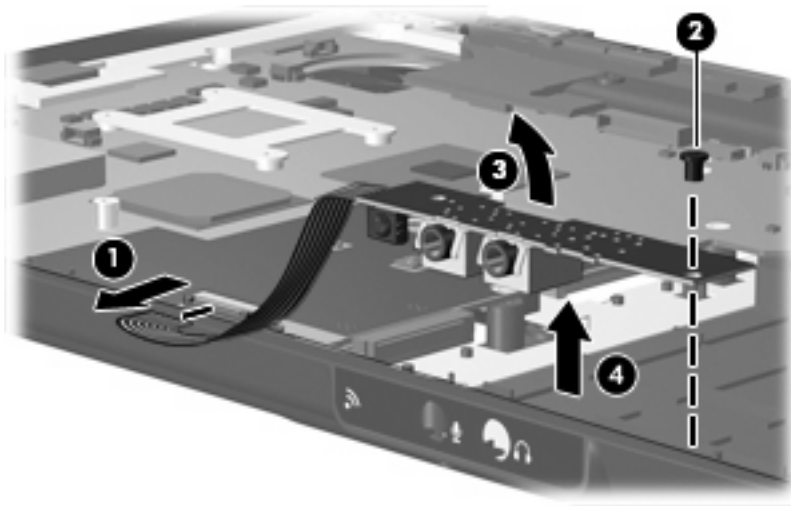

Reverse the above procedure to install the audio board.

Bluetooth module

Description	Spare part number
Bluetooth module (includes Bluetooth module cable)	397923-002

Before removing the Bluetooth module, follow these steps:

1. Shut down the computer. If you are unsure whether the computer is off or in Hibernation, turn the computer on, and then shut it down through the operating system.
2. Disconnect all external devices connected to the computer.
3. Disconnect the power from the computer by first unplugging the power cord from the AC outlet and then unplugging the AC adapter from the computer.

4. Remove the battery (see [Battery on page 53](#)).
5. Remove the following components:
 - a. Hard drive (see [Hard drive on page 54](#))
 - b. WLAN cover (see [WLAN module on page 57](#))
 - c. Optical drive (see [Optical drive on page 64](#))
 - d. Keyboard (see [Keyboard on page 66](#))
 - e. Switch cover (see [Switch cover on page 69](#))
 - f. Display assembly (see [Display assembly on page 71](#))
 - g. Top cover (see [Top cover on page 80](#))
 - h. Audio board (see [Audio board on page 88](#))

Remove the Bluetooth module:

1. Disconnect the Bluetooth module cable **(1)** from the system board.
2. Remove the Bluetooth module **(2)** from the slot built into the base enclosure.

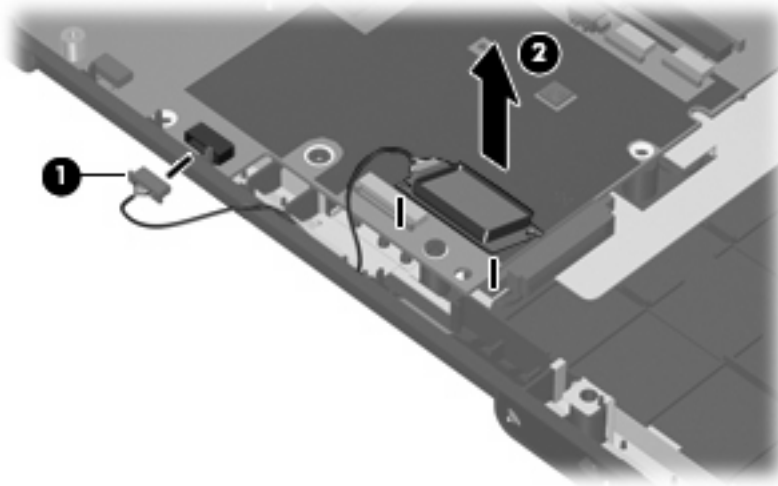

Reverse the above procedure to install the Bluetooth module.

USB board

Description	Spare part number
USB board for use only in computer models with Intel processors (includes USB board cable)	417085-001
USB board for use only in computer models with AMD processors (includes USB board cable)	455859-001

Before removing the USB board, follow these steps:

1. Shut down the computer. If you are unsure whether the computer is off or in Hibernation, turn the computer on, and then shut it down through the operating system.
2. Disconnect all external devices connected to the computer.
3. Disconnect the power from the computer by first unplugging the power cord from the AC outlet and then unplugging the AC adapter from the computer.
4. Remove the battery (see [Battery on page 53](#)).
5. Remove the following components:
 - a. Hard drive (see [Hard drive on page 54](#))
 - b. Wireless module compartment cover (see [WLAN module on page 57](#))
 - c. Optical drive (see [Optical drive on page 64](#))
 - d. Keyboard (see [Keyboard on page 66](#))
 - e. Switch cover (see [Switch cover on page 69](#))
 - f. Display assembly (see [Display assembly on page 71](#))
 - g. Top cover (see [Top cover on page 80](#))

Remove the USB board:

1. Disconnect the USB board cable **(1)** from the system board. The USB board cable is included in the Cable Kit, spare part number 430474-001.
2. Remove the Phillips PM2.5×4.0 screw **(2)** that secures the USB board to the computer.
3. Lift the USB board **(3)** straight up to remove it from the computer.
4. Remove the num lock light **(4)** from the clip built into the base enclosure.

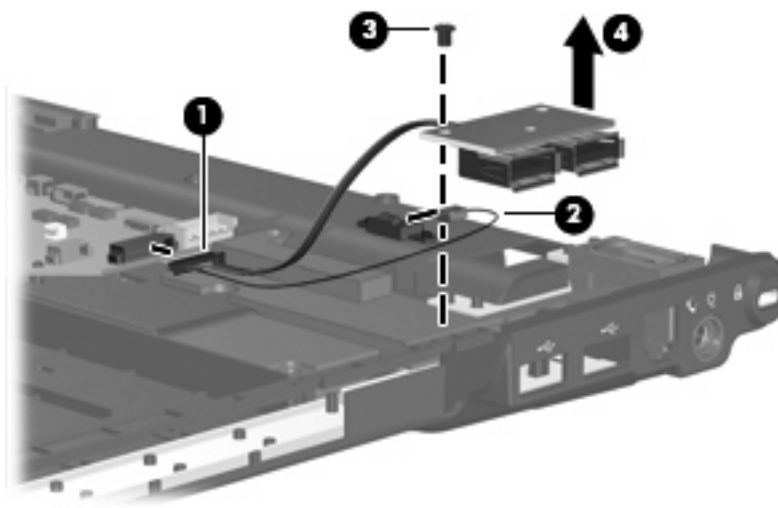

Reverse this procedure to install the USB board.

Speaker assembly

Description	Spare part number
Speaker assembly	417089-001

Before removing the speaker assembly, follow these steps:

1. Shut down the computer. If you are unsure whether the computer is off or in Hibernation, turn the computer on, and then shut it down through the operating system.
2. Disconnect all external devices connected to the computer.
3. Disconnect the power from the computer by first unplugging the power cord from the AC outlet and then unplugging the AC adapter from the computer.
4. Remove the battery (see [Battery on page 53](#)).
5. Remove the following components:
 - a. Hard drive (see [Hard drive on page 54](#))
 - b. Wireless module compartment cover (see [WLAN module on page 57](#))
 - c. Optical drive (see [Optical drive on page 64](#))
 - d. Keyboard (see [Keyboard on page 66](#))
 - e. Switch cover (see [Switch cover on page 69](#))
 - f. Display assembly (see [Display assembly on page 71](#))
 - g. Top cover (see [Top cover on page 80](#))

Remove the speaker assembly:

1. Disconnect the speaker cable **(1)** from the system board.
2. Remove the two Phillips PM2.5×4.0 screws **(2)** that secure the speaker assembly to the computer.

3. Lift the speaker assembly **(3)** straight up to remove it from the computer.

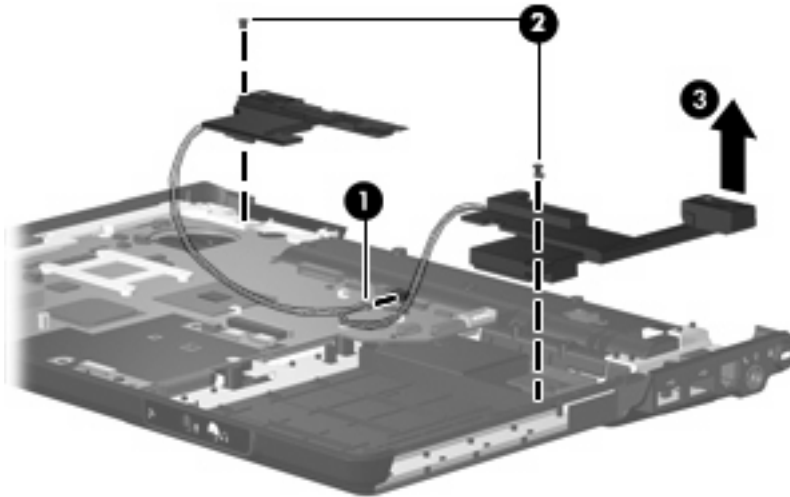

Reverse this procedure to install the speaker assembly.

Power connector cable

Description	Spare part number
Power connector cable for use in computer models with Intel processors	448629-001
Power connector cable for use in computer models with AMD processors	430462-001

Before removing the power connector cable, follow these steps:

1. Shut down the computer. If you are unsure whether the computer is off or in Hibernation, turn the computer on, and then shut it down through the operating system.
2. Disconnect all external devices connected to the computer.
3. Disconnect the power from the computer by first unplugging the power cord from the AC outlet and then unplugging the AC adapter from the computer.
4. Remove the battery (see [Battery on page 53](#)).
5. Remove the following components:
 - a. Hard drive (see [Hard drive on page 54](#))
 - b. Wireless module compartment cover (see [WLAN module on page 57](#))
 - c. Optical drive (see [Optical drive on page 64](#))
 - d. Keyboard (see [Keyboard on page 66](#))
 - e. Switch cover (see [Switch cover on page 69](#))
 - f. Display assembly (see [Display assembly on page 71](#))
 - g. Top cover (see [Top cover on page 80](#))
 - h. Speaker assembly (see [Speaker assembly on page 92](#))

Remove the power connector cable:

1. Disconnect the power connector cable **(1)** from the system board.
2. Remove the power connector **(2)** from the clip built into the base enclosure.

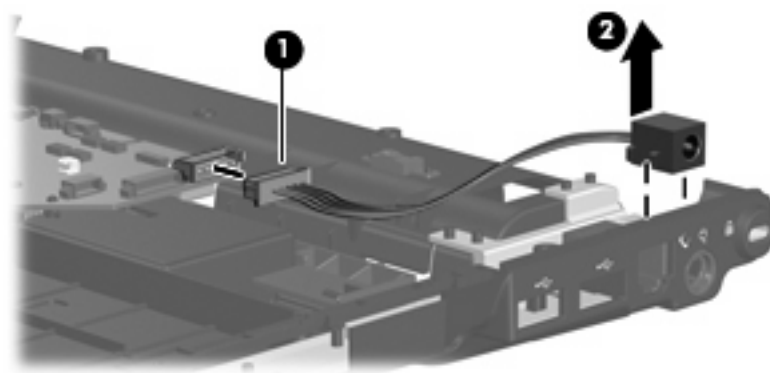

Reverse this procedure to install the power connector cable.

System board

Description	Spare part number
For use only in computer models with Intel processors:	
Equipped with microphones	448596-001
Not equipped with microphones	448598-001
Not equipped with UMA graphics subsystems and with a camera module	460715-001
Equipped with discrete graphics subsystems and with a camera module	460716-001
On defeatured models	460717-001
For use only in computer models with AMD processors:	
Full-featured models without a camera module	453411-001
Defeatured models without a camera module	453412-001
Full-featured models with a camera module	462535-001
Defeatured models with a camera module	462536-001

When replacing the system board, be sure that the following components are removed from the defective system board and installed on the replacement system board:

- RTC battery (see [RTC battery on page 61](#))
- Memory modules (see [Memory module on page 62](#))
- WLAN module (see [WLAN module on page 57](#))
- Modem module (see [Modem module on page 87](#))

Before removing the system board, follow these steps:

1. Shut down the computer. If you are unsure whether the computer is off or in Hibernation, turn the computer on, and then shut it down through the operating system.
2. Disconnect all external devices connected to the computer.
3. Disconnect the power from the computer by first unplugging the power cord from the AC outlet and then unplugging the AC adapter from the computer.
4. Remove the battery (see [Battery on page 53](#)).
5. Remove the following components:
 - a. Hard drive (see [Hard drive on page 54](#))
 - b. Optical drive (see [Optical drive on page 64](#))
 - c. Keyboard (see [Keyboard on page 66](#))
 - d. Switch cover (see [Switch cover on page 69](#))
 - e. Display assembly (see [Display assembly on page 71](#))

- f. Top cover (see [Top cover on page 80](#))
- g. Wireless switch board (see [Wireless switch board on page 85](#))
- h. Audio board (see [Audio board on page 88](#))
- i. Bluetooth module (see [Bluetooth module on page 89](#))
- j. USB board (see [USB board on page 90](#))

Remove the system board:

1. Disconnect the power connector cable **(1)** from the system board.
2. Remove the two black Phillips PM2.5×4.0 screws **(2)** that secure the system board to the computer.

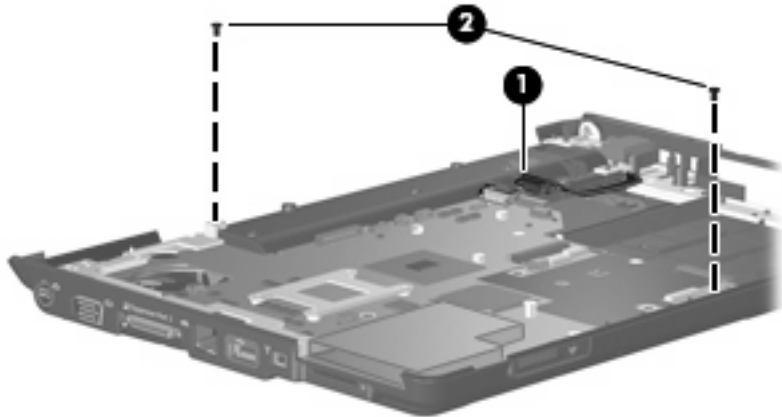

3. Use the optical drive connector **(1)** to lift the right side of the system board until it rests at an angle.
4. Release the system board **(2)** by sliding it to the right at an angle until the connectors on the left side of the system board disengage from the base enclosure.
5. Remove the system board **(3)**.

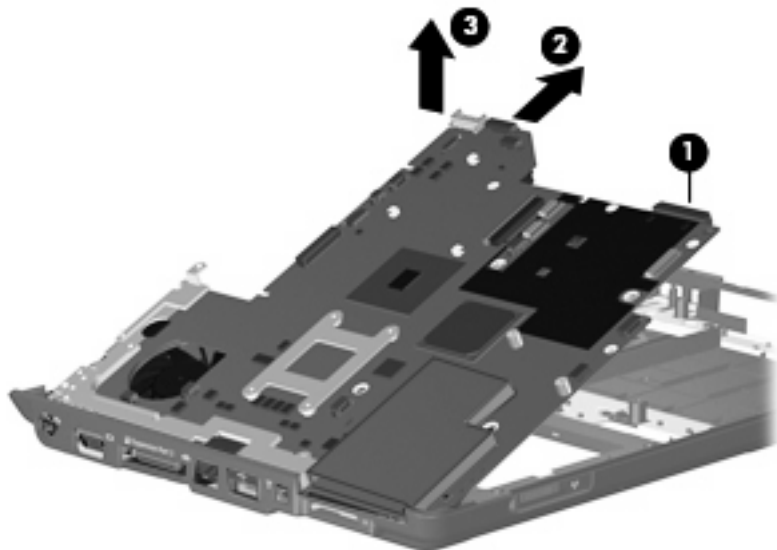

6. If it is necessary to replace the modem module cable, remove the RJ-11 connector **(1)** from the clip built into the base enclosure.
7. Remove the modem module cable **(2)** from the routing channel built into the base enclosure. The modem module cable is included in the Cable Kit, spare part number 430474-001, and is available separately using spare part number 455847-001.

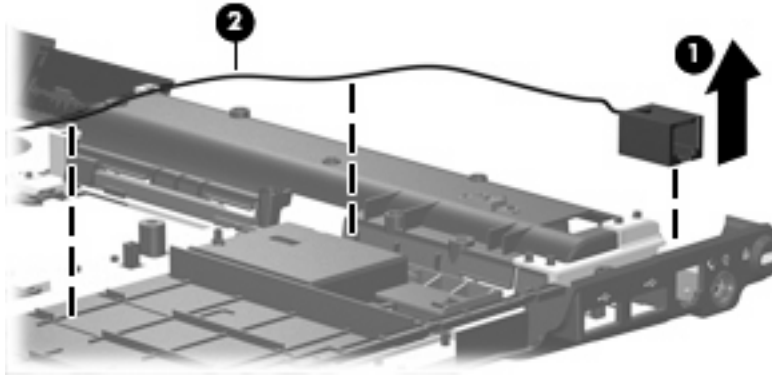

When replacing the system board, be sure that the following components are removed from the defective system board and installed on the replacement system board:

- ExpressCard assembly (see [ExpressCard assembly on page 97](#))
- Fan/heat sink assembly (see [Fan/heat sink assembly on page 100](#))
- Processor (see [Processor on page 103](#))

Reverse the preceding procedure to install the system board.

ExpressCard assembly

Description	Spare part number
ExpressCard assembly	417112-001

Before removing the ExpressCard assembly, follow these steps:

1. Shut down the computer. If you are unsure whether the computer is off or in Hibernation, turn the computer on, and then shut it down through the operating system.
2. Disconnect all external devices connected to the computer.
3. Disconnect the power from the computer by first unplugging the power cord from the AC outlet and then unplugging the AC adapter from the computer.
4. Remove the battery (see [Battery on page 53](#)).
5. Remove the following components:
 - a. Hard drive (see [Hard drive on page 54](#))
 - b. Optical drive (see [Optical drive on page 64](#))
 - c. Keyboard (see [Keyboard on page 66](#))

- d. Switch cover (see [Switch cover on page 69](#))
- e. Display assembly (see [Display assembly on page 71](#))
- f. Top cover (see [Top cover on page 80](#))
- g. Wireless switch board (see [Wireless switch board on page 85](#))
- h. Audio board (see [Audio board on page 88](#))
- i. Bluetooth module (see [Bluetooth module on page 89](#))
- j. USB board (see [USB board on page 90](#))
- k. System board (see [System board on page 95](#))

Remove the ExpressCard assembly:

1. Turn the system board upside down, with the RJ-45 connector toward you.
2. Lift the insulation material **(1)** from the system board to expose the ExpressCard assembly rear screws.
3. Remove the four Phillips PM2.0×4.0 screws **(2)** that secure the ExpressCard assembly to the system board.

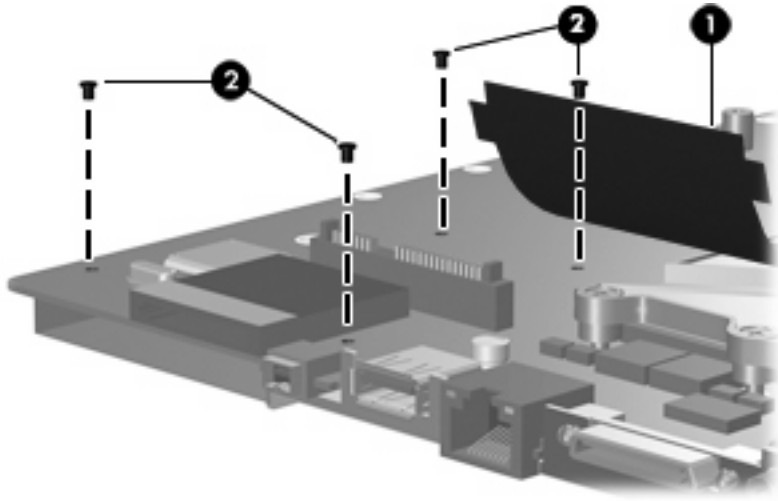

4. Turn the system board right-side up, with the RJ-45 connector toward you.

5. Remove the ExpressCard assembly from the system board.

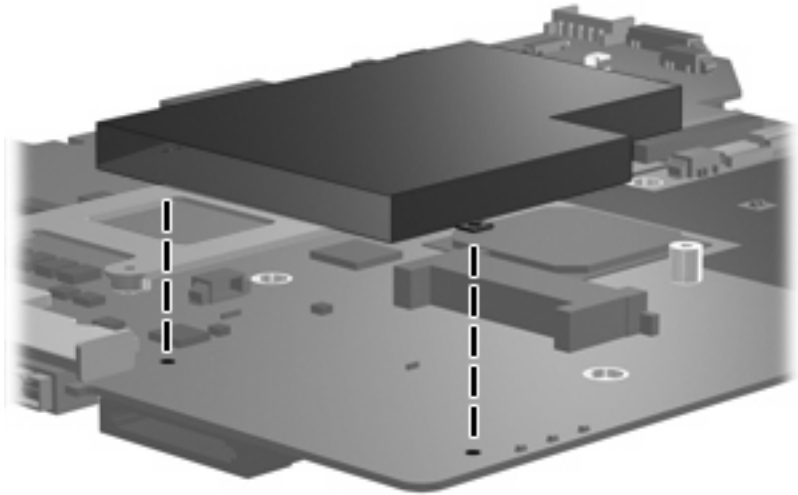

Reverse this procedure to install the ExpressCard assembly.

Fan/heat sink assembly

Description	Spare part number
Fan/heat sink assembly for use in computer models with AMD processors (includes thermal material)	455843-001
Fan/heat sink assembly for use in computer models with Intel processors (includes thermal material)	450096-001

 **NOTE:** To properly ventilate the computer, allow at least a 7.6-cm (3-inch) clearance on the right side and rear panel of the computer. The computer uses an electric fan for ventilation. The fan is controlled by a temperature sensor and is designed to turn on automatically when high temperature conditions exist. These conditions are affected by high external temperatures, system power consumption, power management/battery conservation configurations, battery fast charging, and software requirements. Exhaust air is displaced through the ventilation grill located on the left side of the computer.

Before removing the fan/heat sink assembly, follow these steps:

1. Shut down the computer. If you are unsure whether the computer is off or in Hibernation, turn the computer on, and then shut it down through the operating system.
2. Disconnect all external devices connected to the computer.
3. Disconnect the power from the computer by first unplugging the power cord from the AC outlet and then unplugging the AC adapter from the computer.
4. Remove the battery (see [Battery on page 53](#)).
5. Remove the following components:
 - a. Hard drive (see [Hard drive on page 54](#))
 - b. Optical drive (see [Optical drive on page 64](#))
 - c. Keyboard (see [Keyboard on page 66](#))
 - d. Switch cover (see [Switch cover on page 69](#))
 - e. Display assembly (see [Display assembly on page 71](#))
 - f. Top cover (see [Top cover on page 80](#))
 - g. Wireless switch board (see [Wireless switch board on page 85](#))
 - h. Audio board (see [Audio board on page 88](#))
 - i. Bluetooth module (see [Bluetooth module on page 89](#))
 - j. USB board (see [USB board on page 90](#))
 - k. System board (see [System board on page 95](#))

Remove the fan/heat assembly:

1. Disconnect the fan cable from the system board.

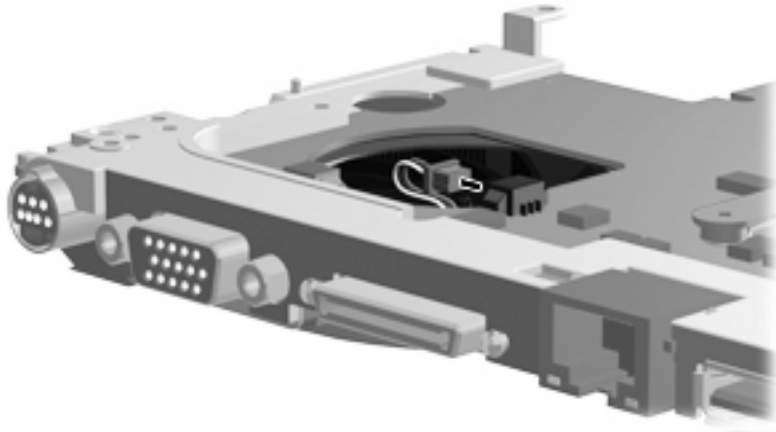

2. Turn the system board upside down, with the external monitor port toward you.
3. Loosen the four Phillips PM2.0×13.0 captive screws **(1)** that secure the fan/heat sink assembly to the system board.

 **NOTE:** Due to the adhesive quality of the thermal material located between the fan/heat sink assembly and system board components, it may be necessary to move the fan/heat sink assembly from side to side to detach the assembly.

4. Remove the fan/heat sink assembly **(2)**.

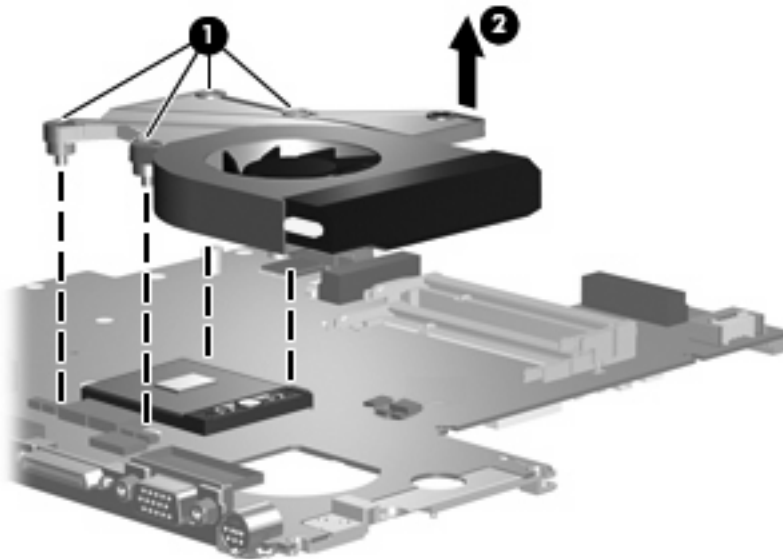

 **NOTE:** The thermal material must be thoroughly cleaned from the surface of the fan/heat sink assembly **(1)** and the processor **(2)** each time the fan/heat sink assembly is removed. Thermal pads and thermal paste must be installed on all surfaces before the fan/heat sink assembly is reinstalled. Thermal pads and thermal paste are included with all fan/heat sink assembly, system board, and processor spare part kits.

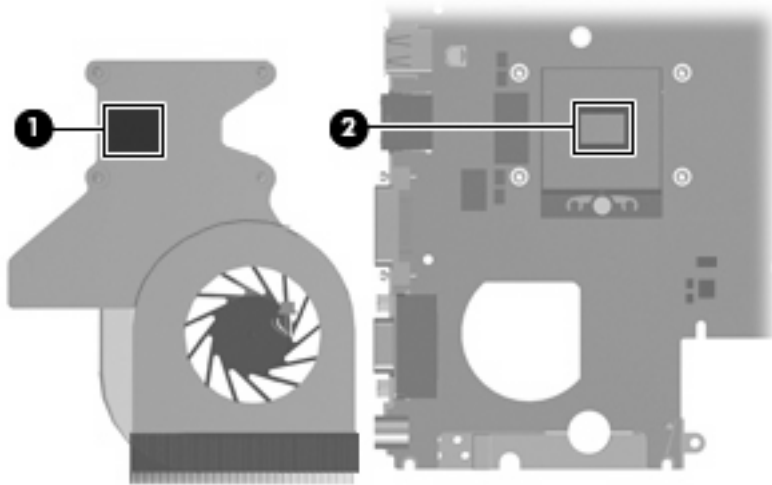

 **NOTE:** The fan/heat sink assembly mounting bracket must be replaced as shown in the following illustration when installing the fan/heat sink assembly.

The fan/heat sink assembly mounting bracket is available using spare part number 417114-001.

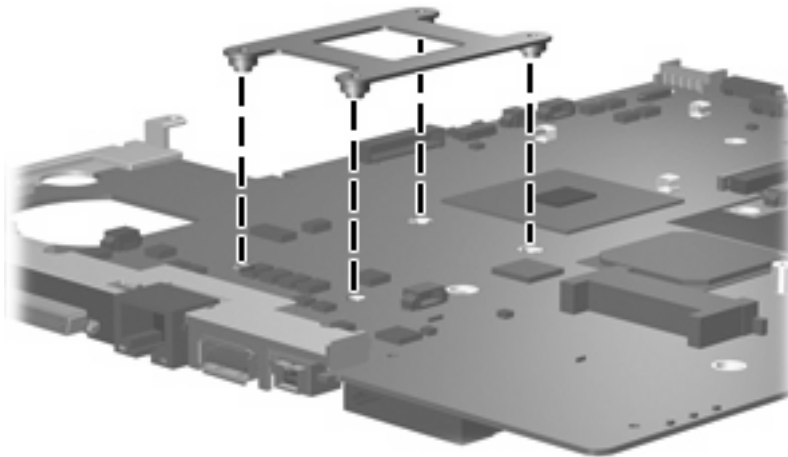

Reverse this procedure to install the fan/heat sink assembly.

Processor

 **NOTE:** All processor spare part kits include thermal material.

Description	Spare part number
Intel Core Duo processors:	
T9300 2.50-GHz processor (6-MB L2 cache)	459799-001
T8300 2.40-GHz processor (3-MB L2 cache)	459798-001
T8100 2.10-GHz processor (3-MB L2 cache)	459797-001
T7700 2.40-GHz processor (4-MB L2 cache)	448148-001
T7500 2.20-GHz processor (4-MB L2 cache)	457312-001
T7300 2.0-GHz processor (4 MB L2 cache)	448601-001
T7250 2.00-GHz processor (2-MB L2 cache)	457311-001
T7100 1.8-GHz processor (2 MB L2 cache)	448600-001
T5750 2.00-GHz processor (2-MB L2 cache)	462353-001
T5550 1.83-GHz processor (2-MB L2 cache)	458247-001
T5450 1.67-GHz processor (2-MB L2 cache)	451597-001
T5250 1.50-GHz processor (2-MB L2 cache)	453948-001
Intel Pentium Dual-Core processors:	
T2370 1.73-GHz processor (1-MB L2 cache)	462354-001
T2330 1.60-GHz processor (1-MB L2 cache)	457314-001
T2310 1.46-GHz processor (1-MB L2 cache)	457313-001
Intel Celeron M processors:	
540 1.86-GHz processor (1-MB L2 cache)	450995-001
530 1.73-GHz processor (1-MB L2 cache)	457315-001
AMD processors:	
Turion TL-68 2.4-GHz processor (1-MB L2 cache)	463917-001
Turion TL-66 2.3-GHz processor (1-MB L2 cache)	450804-001 and 453298-001
Turion TL-62 2.1-GHz processor (1-MB L2 cache)	455809-001
Turion TL-60 2.0-GHz processor (1-MB L2 cache)	455807-001
Turion TL-58 1.9-GHz processor (1-MB L2 cache)	448561-001
Turion TL-55 1.86-GHz processor (1-MB L2 cache)	455808-001
Turion MK-38 2.2-GHz processor (512-MB L2 cache)	449904-001
Athlon TK-57 1.9-GHz processor (2-GB L2 cache)	459759-001
Athlon TK-53 1.7-GHz processor (2-GB L2 cache)	451013-001

Description	Spare part number
Sempron 3800 2.2-GHz processor (256-KB L2 cache)	459760-001
Sempron 3600 2.0-GHz processor (256-KB L2 cache)	450609-001

Before removing the processor, follow these steps:

1. Shut down the computer. If you are unsure whether the computer is off or in Hibernation, turn the computer on, and then shut it down through the operating system.
2. Disconnect all external devices connected to the computer.
3. Disconnect the power from the computer by first unplugging the power cord from the AC outlet and then unplugging the AC adapter from the computer.
4. Remove the battery (see [Battery on page 53](#)).
5. Remove the following components:
 - a. Hard drive (see [Hard drive on page 54](#))
 - b. Optical drive (see [Optical drive on page 64](#))
 - c. Keyboard (see [Keyboard on page 66](#))
 - d. Switch cover (see [Switch cover on page 69](#))
 - e. Display assembly (see [Display assembly on page 71](#))
 - f. Top cover (see [Top cover on page 80](#))
 - g. Wireless switch board (see [Wireless switch board on page 85](#))
 - h. Audio board (see [Audio board on page 88](#))
 - i. Bluetooth module (see [Bluetooth module on page 89](#))
 - j. USB board (see [USB board on page 90](#))
 - k. System board (see [System board on page 95](#))
 - l. Fan/heat sink assembly (see [Fan/heat sink assembly on page 100](#))

Remove the processor:

1. Turn the processor locking screw **(1)** one-half turn counterclockwise until you hear a click.

2. Lift the processor **(2)** straight up and remove it.

 **NOTE:** The gold triangle **(3)** on the processor must be aligned with the triangle icon **(4)** embossed on the processor slot when you install the processor.

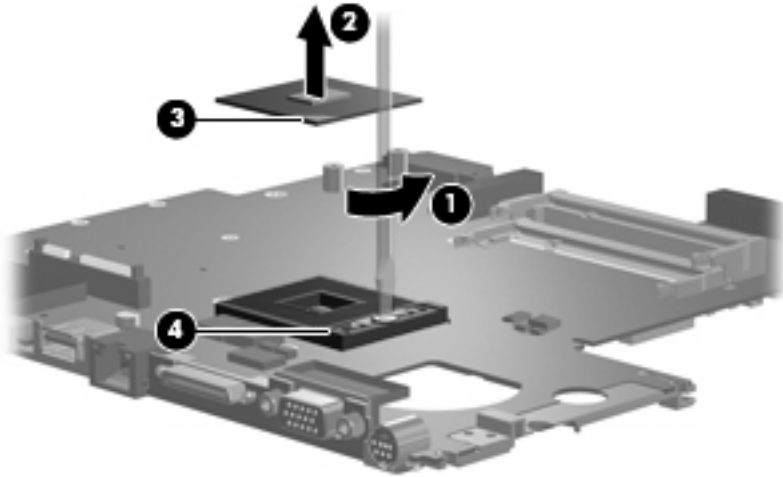

Reverse this procedure to install the processor.

5 Setup Utility

 **WARNING!** Only authorized technicians trained by HP must repair this equipment. All troubleshooting and repair procedures are detailed to allow repair at only the subassembly or module level. Because of the complexity of the individual boards and subassemblies, do not attempt to make repairs at the component level or modify any printed wiring board. Improper repairs can create a safety hazard. Any indication of component replacement or printed wiring board modification may void any warranty or exchange allowances.

Starting the Setup Utility

The Setup Utility is a ROM-based information and customization utility that can be used even when your Windows® operating system is not working or will not load.

 **NOTE:** The fingerprint reader (select models only) does not work when accessing the Setup Utility.

The utility reports information about the computer and provides settings for startup, security, and other preferences.

To start the Setup Utility:

1. Turn on or restart the computer.
2. Before Windows opens and while “Press <F10> to enter setup” is displayed in the lower-left corner of the screen, press **f10**.

Changing the language of the Setup Utility

The following procedure explains how to change the language of the Setup Utility. If the Setup Utility is not already running, begin at step 1. If the Setup Utility is already running, begin at step 2.

1. To start the Setup Utility, turn on or restart the computer, and then press **f10** while “Press <F10> to enter setup” is displayed in the lower-left corner of the screen.
2. Use the arrow keys to select **System Configuration > Language**, and then press **enter**.
3. Press **f5** or **f6** (or use the arrow keys) to select a language, and then press **enter** to select a language.
4. When a confirmation prompt with your preference selected is displayed, press **enter** to save your preference.
5. To set your preferences and exit the Setup Utility, press **f10** and then follow the instructions on the screen.

Your preferences go into effect when the computer restarts in Windows.

Navigating and selecting in the Setup Utility

Because the Setup Utility is not Windows-based, it does not support the TouchPad. Navigation and selection are by keystroke.

- To choose a menu or a menu item, use the arrow keys.
- To choose an item in a drop-down list or to toggle a field, for example an Enable/Disable field, use either the arrow keys or **f5** or **f6**.
- To select an item, press **enter**.
- To close a text box or return to the menu display, press **esc**.
- To display additional navigation and selection information while the Setup Utility is open, press **f1**.

Displaying system information

The following procedure explains how to display system information in the Setup Utility. If the Setup Utility is not open, begin at step 1. If the Setup Utility is open, begin at step 2.

1. To start the Setup Utility, turn on or restart the computer, and then press **f10** while “Press <F10>to enter setup” is displayed in the lower-left corner of the screen.
2. Access the system information by using the **Main** menu.
3. To exit the Setup Utility without changing any settings, use the arrow keys to select **Exit > Exit Discarding Changes**, and then press **enter**. (The computer restarts in Windows.)

Restoring default settings in the Setup Utility

The following procedure explains how to restore the Setup Utility default settings. If the Setup Utility is not already running, begin at step 1. If the Setup Utility is already running, begin at step 2.

1. To start the Setup Utility, turn on or restart the computer, and then press **f10** while “Press <F10>to enter setup” is displayed in the lower-left corner of the screen.
2. Select **Exit > Load Setup Defaults**, and then press **enter**.
3. When the Setup Confirmation is displayed, press **enter** to save your preferences.
4. To set your preferences and exit the Setup Utility, press **f10**, and then follow the instructions on the screen.

The Setup Utility default settings are set when you exit the Setup Utility and go into effect when the computer restarts.

 **NOTE:** Your password, security, and language settings are not changed when you restore the factory default settings.

Using advanced Setup Utility features

This section describes the Setup Utility features recommended for all users. For more information about the Setup Utility features recommended for advanced users only, refer to Help and Support, which is accessible only when the computer is in Windows.

The Setup Utility features available for advanced users include a hard drive self-test, a Network Service Boot, and settings for boot order preferences.

The “<F12> to boot from LAN” message that is displayed in the lower-left corner of the screen each time the computer is started or restarted in Windows is the prompt for a Network Service Boot.

The “Press <F9> to change boot order” message that is displayed in the lower-left corner of the screen each time the computer is started or restarted in Windows is the prompt to change the boot order.

Closing the Setup Utility

You can close the Setup Utility with or without saving changes.

- To close the Setup Utility and save your changes from the current session, use either of the following procedures:

- Press **f10**, and then follow the instructions on the screen.

—or—

- If the Setup Utility menus are not visible, press **esc** to return to the menu display. Then use the arrow keys to select **Exit > Exit Saving Changes**, and then press **enter**.

When you use the **f10** procedure, you are offered an option to return to the Setup Utility. When you use the Exit Saving Changes procedure, the Setup Utility closes when you press **enter**.

- To close the Setup Utility without saving your changes from the current session:

If the Setup Utility menus are not visible, press **esc** to return to the menu display. Then use the arrow keys to select **Exit > Exit Discarding Changes**, and then press **enter**.

After the Setup Utility closes, the computer restarts in Windows.

Setup Utility menus

The menu tables in this section provide an overview of Setup Utility options.

 **NOTE:** Some of the Setup Utility menu items listed in this section may not be supported by your computer.

Main menu

Select	To do this
System information	<ul style="list-style-type: none">• View and change the system time and date.• View identification information about the computer.• View specification information about the processor, memory size, system BIOS, and keyboard controller version (select models only).

Security menu

Select	To do this
Administrator password	Enter, change, or delete an administrator password.
Power-On Password	Enter, change, or delete a power-on password.

System Configuration menu

Select	To do this
Language Support	Change the Setup Utility language.
Boot Options	Set the following boot options: <ul style="list-style-type: none">• f10 and f12 Delay (sec.)—Set the delay for the f10 and f12 functions of the Setup Utility in intervals of 5 seconds each (0, 5, 10, 15, 20).• CD-ROM boot—Enable/disable boot from CD-ROM.• Floppy boot—Enable/disable boot from Floppy.• Internal Network Adapter boot—Enable/disable boot from Internal Network Adapter.• Boot Order—Set the boot order for:<ul style="list-style-type: none">◦ USB Floppy◦ ATAPI CD/DVD ROM Drive◦ Hard drive◦ USB Diskette on Key◦ USB Hard drive◦ Network adapter
Button Sound (select models only)	Enable/disable the Quick Launch Button tapping sound.
Dedicated Video Memory*	Select amount of dedicated video memory.
Virtualization Technology*	Enable/disable the processor Virtualization Technology.
Processor C4 State	Enable/disable the processor C4 sleep state.

*Available for AMD processors.

Diagnostics menu

Select	To do this
Hard Drive Self Test	Run a comprehensive self-test on the hard drive. NOTE: On models with two hard drives, this menu option is called the Primary Hard Disk Self Test .
Secondary Hard Drive Self Test (select models only)	Run a comprehensive self-test on a secondary hard drive.

Select	To do this
Memory Test*	Run a diagnostic test on system memory.

*Available for AMD processors.

6 Specifications

Computer specifications

	Metric	U.S.
Dimensions		
Height (front to back)	2.60 to 3.90 cm	1.02 to 1.54 in
Width	33.40 cm	13.15 in
Depth	23.70 cm	9.33 in
Weight (with optical drive, hard drive, and battery)	2.50 g	5.50 lbs
Input power		
Operating voltage	18.5 V dc — 19.0 V dc	
Operating current	3.5 A or 4.74 A	
Temperature		
Operating (not writing to optical disc)	0°C to 35°C	32°F to 95°F
Operating (writing to optical disc)	5°C to 35°C	41°F to 95°F
Nonoperating	-20°C to 60°C	-4°F to 140°F
Relative humidity		
Operating	10% to 90%	
Nonoperating	5% to 95%	
Maximum altitude (unpressurized)		
Operating (14.7 to 10.1 psia)	-15 m to 3,048 m	-50 ft to 10,000 ft
Nonoperating (14.7 to 4.4 psia)	-15 m to 12,192 m	-50 ft to 40,000 ft
Shock		
Operating	125 g, 2 ms, half-sine	
Nonoperating	200 g, 2 ms, half-sine	
Random vibration		
Operating	0.75 g zero-to-peak, 10 Hz to 500 Hz, 0.25 oct/min sweep rate	

	Metric	U.S.
Nonoperating	1.50 g zero-to-peak, 10 Hz to 500 Hz, 0.5 oct/min sweep rate	

NOTE: Applicable product safety standards specify thermal limits for plastic surfaces. The computer operates well within this range of temperatures.

14.1-inch, WXGA, BrightView display specifications

	Metric	U.S.
Dimensions		
Height	27.94 cm	11.0 in
Width	20.83 cm	8.2 in
Diagonal	35.56 cm	14.1 in
Number of colors	Up to 16.8 million	
Contrast ratio	250:1 (typical)	
Brightness	180 nits (typical)	
Pixel resolution		
Pitch	0.279 × 0.279 mm	
Format	1280 × 800	
Configuration	RGB vertical stripe	
Backlight	Edge lit	
Character display	80 × 25	
Total power consumption	4 W	
Viewing angle	+/-40° horizontal, +20/-40° vertical (typical)	

Hard drive specifications

	250-GB*	160-GB*	120-GB*	80-GB*
Dimensions				
Height	9.5 mm	9.5 mm	9.5 mm	9.5 mm
Width	70 mm	70 mm	70 mm	70 mm
Weight	102 g	102 g	102 g	102 g
Interface type				
	SATA	SATA	SATA	SATA
Transfer rate				
Synchronous (maximum)	100 MB/sec	100 MB/sec	100 MB/sec	100 MB/sec
Security	ATA security	ATA security	ATA security	ATA security
Seek times (typical read, including setting)				
Single track	3 ms	3 ms	3 ms	3 ms
Average	13 ms	13 ms	13 ms	13 ms
Maximum	24 ms	24 ms	24 ms	24 ms
Logical blocks				
	495,702,655	317,249,699	237,937,274	158,624,849
Disk rotational speed				
	5400 rpm			
Operating temperature				
	5°C to 55°C (41°F to 131°F)			
NOTE: Certain restrictions and exclusions apply. Consult technical support for details.				
*1 GB = 1 billion bytes when referring to hard drive storage capacity. Accessible capacity is less. Actual drive specifications may differ slightly.				

DVD±RW and CD-RW Super Multi Double-Layer Combo Drive specifications

Applicable disc	Read:	Write:
	CD-DA, CD+(E)G, CD-MIDI, CD-TEXT, CD-ROM, CD-ROM XA, MIXED MODE CD, CD-I, CD-I Bridge (Photo-CD, Video CD), Multisession CD (Photo-CD, CD-EXTRA, Portfolio, CD-R, CD-RW), CD-R, CD-RW, DVD-ROM (DVD-5, DVD-9, DVD-10, DVD-18), DVD-R, DVD-RW, DVD+R, DVD+RW, DVD-RAM	CD-R and CD-RW DVD+R, DVD+RW, DVD-R, DVD-RW, DVD-RAM
Center hole diameter	1.5 cm (0.59 in)	
Disc diameter		
Standard disc	12 cm (4.72 in)	
Mini disc	8 cm (3.15 in)	
Disc thickness	1.2 mm (0.047 in)	
Track pitch	0.74 μm	
Access time	CD	DVD
Random	< 175 ms	< 230 ms
Full stroke	< 285 ms	< 335 ms
Audio output level	Audio-out, 0.7 Vrms	
Cache buffer	2 MB	
Data transfer rate		
24X CD-ROM	3,600 KB/sec	
8X DVD	10,800 KB/sec	
24X CD-R	3,600 KB/sec	
16X CD-RW	2,400 KB/sec	
8X DVD+R	10,800 KB/sec	
4X DVD+RW	5,400 KB/sec	
8X DVD-R	10,800 KB/sec	
4X DVD-RW	5,400 KB/sec	
2.4X DVD+R(9)	2,700 KB/sec	
5X DVD-RAM	6,750 KB/sec	
Transfer mode	Multiword DMA Mode	
Startup time	< 15 seconds	
Stop time	< 6 seconds	

System DMA specifications

Hardware DMA	System function
DMA0	Not applicable
DMA1*	Not applicable
DMA2*	Not applicable
DMA3	Not applicable
DMA4	Direct memory access controller
DMA5*	Available for PC Card†
DMA6	Not assigned
DMA7	Not assigned

*PC Card controller can use DMA 1, 2, or 5.

†Not assigned for computer models with AMD processors.

System interrupt specifications—Intel processors

Hardware IRQ	System function
IRQ0	System timer
IRQ1	Standard 101-/102-Key or Microsoft® Natural Keyboard
IRQ2	Cascaded
IRQ3	Intel 82801DB/DBM USB2 Enhanced Host Controller—24CD
IRQ4	COM1
IRQ5*	Conexant AC—Link Audio Intel 82801DB/DBM SMBus Controller—24C3 Data Fax Modem with SmartCP
IRQ6	Diskette drive
IRQ7*	Parallel port
IRQ8	System CMOS/real-time clock
IRQ9*	Microsoft ACPI-compliant system
IRQ10*	Intel USB UHCI controller—24C2 Intel 82852/82855 GM/GME Graphic Controller Realtek RTL8139 Family PCI Fast Ethernet Controller
IRQ11	Intel USB EHCI controller—24CD Intel USB UHCI controller—24C4 Intel USB UHCI controller—24C7 Intel Pro/Wireless 2200BG TI OHCI 1394 host controller TI PCI1410 CardBus controller
IRQ12	Synaptics PS/2 TouchPad
IRQ13	Numeric data processor
IRQ14	Primary IDE channel
IRQ15	Secondary IDE channel

*Default configuration; audio possible configurations are IRQ5, IRQ7, IRQ9, IRQ10, or none.

NOTE: PC Cards may assert IRQ3, IRQ4, IRQ5, IRQ7, IRQ9, IRQ10, IRQ11, or IRQ15. Either the infrared or the serial port may assert IRQ3 or IRQ4.

System interrupt specifications—AMD processors

Hardware IRQ	System function
ISA0	High precision event timer
ISA1	Standard 101/102-Key or Microsoft Natural PS/2 Keyboard
ISA8	High precision event timer
ISA12	Alps Pointing-device (2 way)
ISA13	Numeric data processor
ISA14	ATA Channel 0
ISA15	ATA Channel 1
PCI5	Ricoh OHCI Compliant IEEE 1394 Host Controller
PCI7	Ricoh Memory Stick Controller
PCI7	Ricoh SD/MMC Host Controller
PCI7	Ricoh xD-Picture Card Controller
PCI7	SDA Standard Compliant SD Host Controller
PC10	nVidia nForce PCI System Management
PC16	Standard Enhanced PCI to USB Host Controller
PC16	Standard OpenHCD USB Host Controller
PC17	Standard Enhanced PCI to USB Host Controller
PC17	Standard OpenHCD USB Host Controller
PC18	nVidia nForce PCI System Management
PC19	Broadcom 802.11b/g WLAN
PCI-2	PCI standard PCI-to-PCI bridge
PC21	High Definition Audio Controller
PC22	Standard Dual Channel PCI IDE Controller
PC23	nVidia MCP67M
PC-3	PCI standard PCI-to-PCI bridge
PC-4	nVidia nForce Networking Controller

System I/O address specifications—Intel processors

I/O address (hex)	System function (shipping configuration)
000 - 00F	DMA controller no. 1
010 - 01F	Unused
020 - 021	Interrupt controller no. 1
022 - 024	Opti chipset configuration registers
025 - 03F	Unused
02E - 02F	87334 "Super I/O" configuration for CPU
040 - 05F	Counter/timer registers
044 - 05F	Unused
060	Keyboard controller
061	Port B
062 - 063	Unused
064	Keyboard controller
065 - 06F	Unused
070 - 071	NMI enable/RTC
072 - 07F	Unused
080 - 08F	DMA page registers
090 - 091	Unused
092	Port A
093 - 09F	Unused
0A0 - 0A1	Interrupt controller no. 2
I/O Address (hex)	System Function (shipping configuration)
0A2 - 0BF	Unused
0C0 - 0DF	DMA controller no. 2
0E0 - 0EF	Unused
0F0 - 0F1	Coprocessor busy clear/reset
0F2 - 0FF	Unused
100 - 16F	Unused
170 - 177	Secondary fixed disk controller
178 - 1EF	Unused
1F0 - 1F7	Primary fixed disk controller
1F8 - 200	Unused
201	JoyStick (decoded in ESS1688)
202 - 21F	Unused

I/O address (hex)	System function (shipping configuration)
220 - 22F	Entertainment audio
230 - 26D	Unused
26E - 26	Unused
278 - 27F	Unused
280 - 2AB	Unused
2A0 - 2A7	Unused
2A8 - 2E7	Unused
2E8 - 2EF	Reserved serial port
2F0 - 2F7	Unused
2F8 - 2FF	Infrared port
300 - 31F	Unused
320 - 36F	Unused
370 - 377	Secondary diskette drive controller
378 - 37F	Parallel port (LPT1/default)
380 - 387	Unused
388 - 38B	FM synthesizer—OPL3
38C - 3AF	Unused
3B0 - 3BB	VGA
3BC - 3BF	Reserved (parallel port/no EPP support)
3C0 - 3DF	VGA
3E0 - 3E1	PC Card controller in CPU
3E2 - 3E3	Unused
3E8 - 3EF	Internal modem
3F0 - 3F7	"A" diskette controller
3F8 - 3FF	Serial port (COM1/default)
CF8 - CFB	PCI configuration index register (PCIDIVO-1)
CFC - CFF	PCI configuration data register (PCIDIVO-1)

System I/O address specifications—AMD processors

I/O address (hex)	System function (shipping configuration)
000 - 008	Direct memory access controller
000 - CF7	PCI Bus
00A - 00F	Direct memory access controller
010 - 01F	Motherboard resources
020 - 021	Programmable interrupt controller
022 - 03F	Motherboard resources
040 - 043	System timer
044 - 05F	Motherboard resources
060 - 060	Standard 101/102-Key or Microsoft Natural PS/2 Keyboard
061 - 061	System speaker
062 - 062	Microsoft ACPI-Compliant Embedded Controller
063 - 063	Motherboard resources
064 - 064	Standard 101/102-Key or Microsoft Natural PS/2 Keyboard
065 - 065	Motherboard resources
066 - 066	Microsoft ACPI-Compliant Embedded Controller
067 - 06F	Motherboard resources
070 - 071	System CMOS/real time clock
072 - 073	Motherboard resources
074 - 07f	Motherboard resources
080 - 080	Motherboard resources
081 - 083	Direct memory access controller
087 - 087	Direct memory access controller
089 - 08B	Direct memory access controller
08F - 08F	Direct memory access controller
091 - 093	Motherboard resources
097 - 09F	Motherboard resources
0A0 - 0A1	Programmable interrupt controller
0A2 - 0BF	Motherboard resources
0C0 - 0D1	Direct memory access controller
0D4 - 0DF	Direct memory access controller
0E0 - 0EF	Motherboard resources
0F0 - 0F1	Numeric data processor
1F0 - 1F7	ATA Channel 0

I/O address (hex)	System function (shipping configuration)
360 - 361	Motherboard resources
376 - 376	ATA Channel 1
3B0 - 3BB	nVidia MCP67M
3C0 - 3DF	nVidia MCP67M
3F6 - 3F6	ATA Channel 0
4D0 - 4D1	Motherboard resources
0D00 - FFFF	PCI bus
1000 - 107F	Motherboard resources
1080 - 10FF	Motherboard resources
1400 - 147F	Motherboard resources
1480 - 14FF	Motherboard resources
1800 - 187F	Motherboard resources
1880 - 18FF	Motherboard resources
3000 - 303F	nVidia nFOrce PCI System Management
3040 - 307F	nVidia nFOrce PCI System Management
3080 - 30BF	nVidia nFOrce PCI System Management
30C0 - 30CF	Standard Dual Channel PCI IDE Controller
30D0 - 30DF	Standard Dual Channel PCI IDE Controller
30E0 - 30E3	Standard Dual Channel PCI IDE Controller
30E4 - 30E7	Standard Dual Channel PCI IDE Controller
30E8 - 30EF	Standard Dual Channel PCI IDE Controller
30F0 - 30F7	Standard Dual Channel PCI IDE Controller
400 - 4FFF	PCI standard PCI-to-PCI bridge

System memory map specifications—Intel processors

Size	Memory address	System function
640 KB	00000000-0009FFFF	Base memory
128 KB	000A0000-000BFFFF	Video memory
48 KB	000C0000-000CBFFF	Video BIOS
160 KB	000C8000-000E7FFF	Unused
64 KB	000E8000-000FFFFF	System BIOS
15 MB	00100000-00FFFFFF	Extended memory
58 MB	04800000-07FFFFFF	Super extended memory
58 MB	04800000-07FFFFFF	Unused
2 MB	08000000-080FFFFF	Video memory (direct access)
4 GB	08200000-FFFFFFF	Unused
64 KB	FFFF0000-FFFFFFFF	System BIOS

System memory map specifications—AMD processors

Memory address	System function
000A0000 - 000BFFFF	nVidia MCP67M
000A0000 - 000BFFFF	PCI bus
000C0000 - 000C3FFF	PCI bus
000C4000 - 000C7FFF	PCI bus
000C8000 - 000CBFFF	PCI bus
000CC000 - 000CFFFF	PCI bus
000D000 - 000D3FFF	PCI bus
000D4000 - 000D7FFF	PCI bus
000D800 - 000DBFFF	PCI bus
000DC00 - 000DFFFF	PCI bus
000E0000 - 000E3FFF	PCI bus
000E4000 - 000E7FFF	PCI bus
000E800 - 000EBFFF	PCI bus
000EC00 - 000EFFFF	PCI bus
000F0000 - 000FFFFF	PCI bus
4000000 - FEBFFFFF	PCI bus
D0000000 - DFFFFFFF	nVidia MCP67M
E000000 - EFFFFFFF	Motherboard resources
F00000 - F3FFFFFF	PCI standard PCI-to-PCI bridge
F4000000 - F4FFFFFF	nVidia MCP67M
F5000000 - F5FFFFFF	nVidia MCP67M
F6000000 - F6003FFF	Broadcom 802.11b/g WLAN
F600000 - F60FFFFF	PCI standard PCI-to-PCI bridge
F610000 - F61007FF	RICOH OHCI Compliant IEEE 1394 Host Controller
F6100000 - F61FFFFF	PCI standard PCI-to-PCI bridge
F6100800 - F61008FF	SDA Standard Compliant SD Host Controller
F6100C00 - F6100CFF	Ricoh SD/MMC Host Controller
F6101000 - F61010FF	Ricoh Memory Stick Controller
F6101400 - F61014FF	Ricoh xD-Picture Card Controller
F620000 - F627FFFF	nVidia nForce System Management Controller
F6480000 - F6483FFF	High Definition Audio Controller
F6484000 - F6485FFF	Standard Dual Channel PCI IDE Controller

Memory address	System function
F6486000 - F6486FFF	Standard OpenHCD USB Host Controller
F6487000 - F6487FFF	Standard OpenHCD USB Host Controller
F6488000 - F6488FFF	nVidia nForce Networking Controller
F6489000 - F64890FF	Standard Enhanced PCI to USB Host Controller
FF6489400 - F64894FF	Standard Enhanced PCI to USB Host Controller
F6489800 - F648980F	nVidia nForce Networking Controller
F6489C00 - F6489CFF	nVidia nForce Networking Controller
FEC00000 - FEC00FFF	System board
FEC80000 - FEC80FFF	System board
FED00000 - FED003FF	High precision event timer
FEE00000 - FEEFFFFFF	System board
FEF00000 - FEF00FFF	System board
FFC00000 - FFFFFFFF	System board

7 Screw listing

This section provides specification and reference information for the screws and screw locks used in the computer. All screws and screw locks listed in this section are available in the Screw Kit, spare part number 417109-001 for computers with Intel processors, 455867-001 for computers with AMD processors, and the Display Screw Kit, spare part number 417105-001 for computers with Intel processors, 455868-001 for computers with AMD processors.

Phillips PM2.0×5.0 captive screw

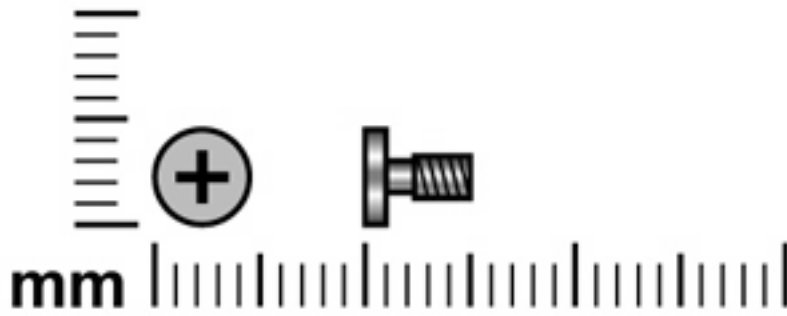

Color	Quantity	Length	Thread	Head diameter
Black	5	5.0 mm	2.0 mm	5.0 mm

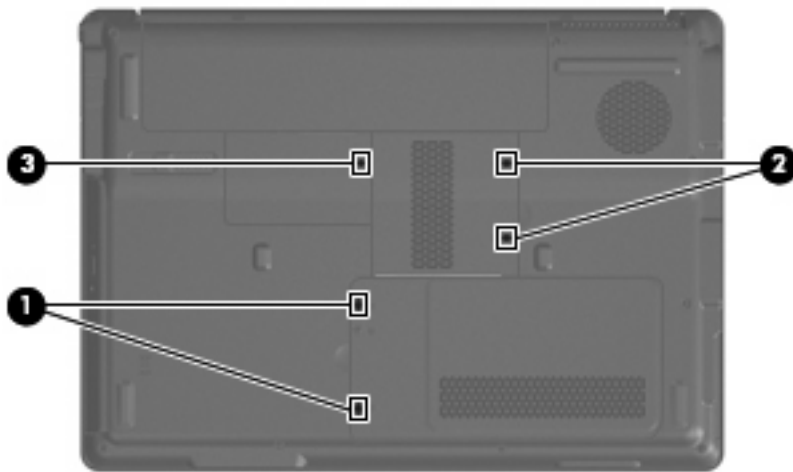

Where used:

- (1)** Two captive screws (secured by C-clips) that secure the hard drive cover to the computer
- (2)** Two captive screws (secured by C-clips) that secure the memory module compartment cover to the computer
- (3)** One captive screw (secured by a C-clip) that secures the wireless module compartment cover to the computer

Phillips PM2.5×4.0 screw

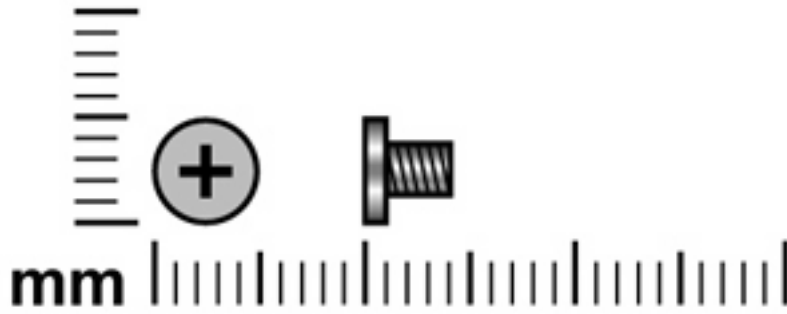

Color	Quantity	Length	Thread	Head diameter
Black	9	4.0 mm	2.5 mm	5.0 mm

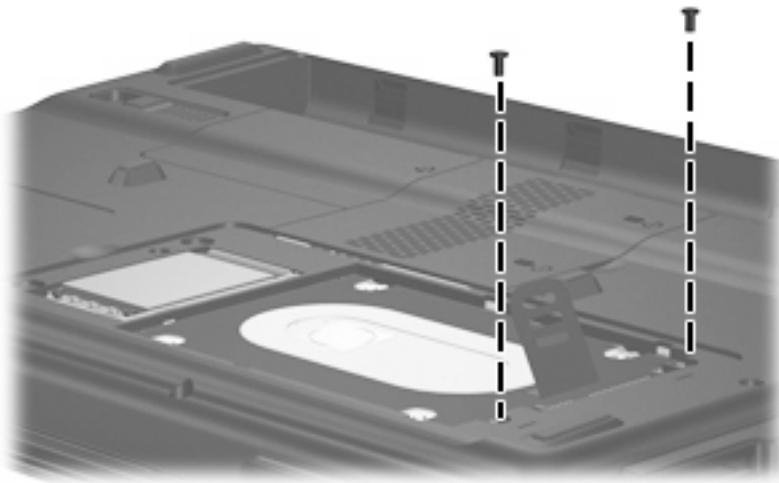

Where used: 2 screws that secure the hard drive to the computer

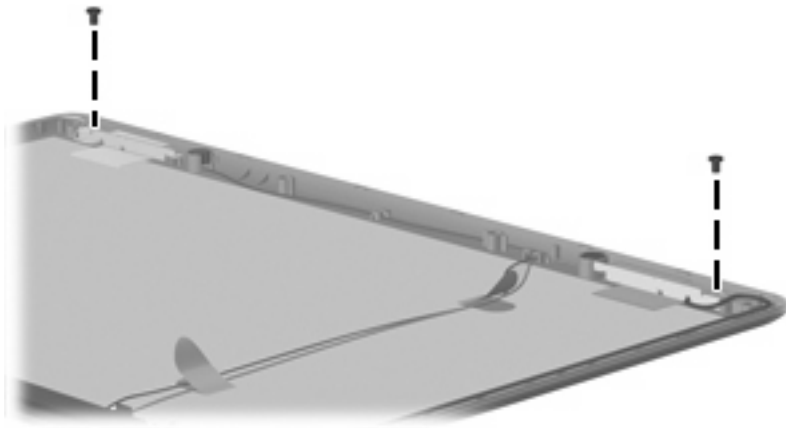

Where used: 2 screws that secure the wireless antenna transceivers to the display enclosure

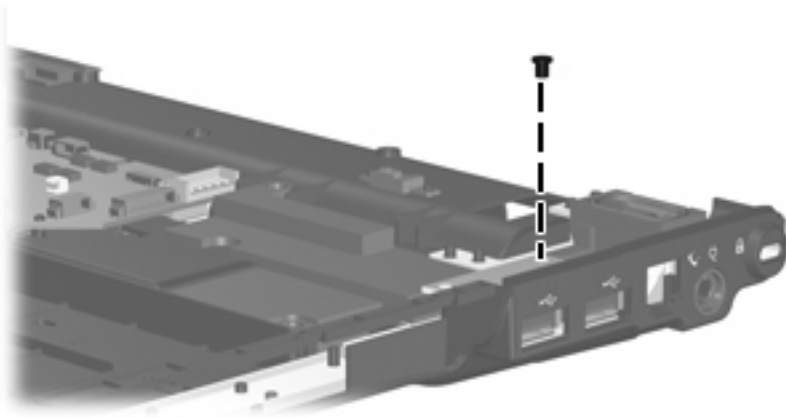

Where used: One screw that secures the USB board to the computer

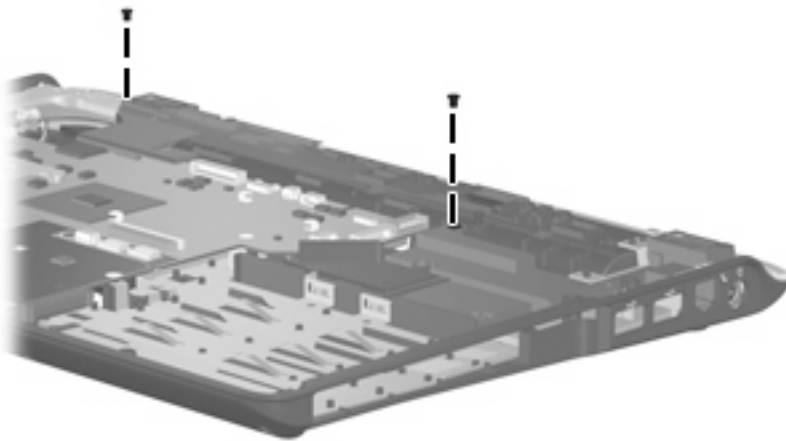

Where used: 2 screws that secure the speaker assembly to the computer

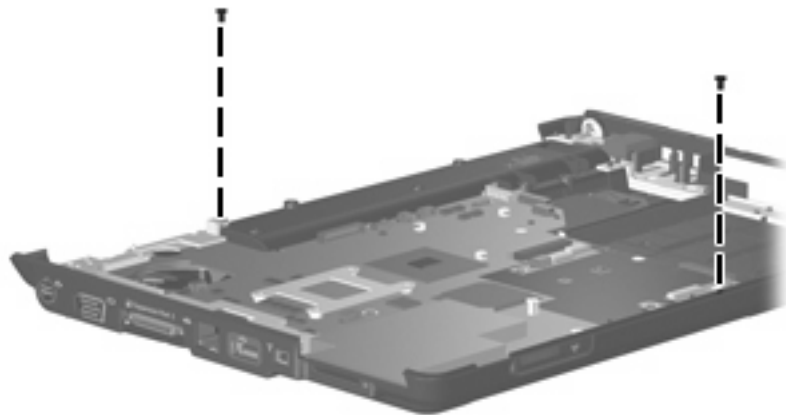

Where used: 2 screws that secure the system board to the computer

Phillips PM3.0×4.0 screw

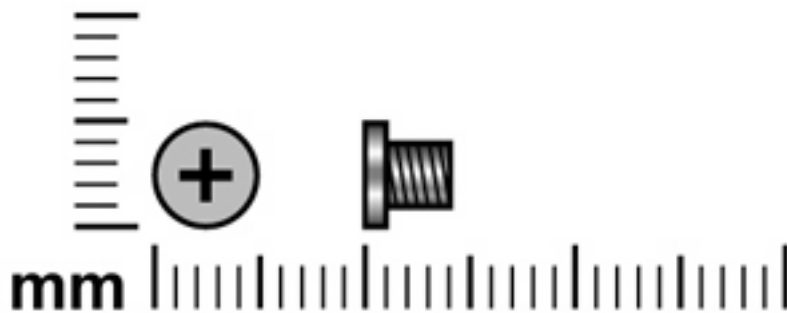

Color	Quantity	Length	Thread	Head diameter
Silver	4	4.0 mm	3.0 mm	5.0 mm

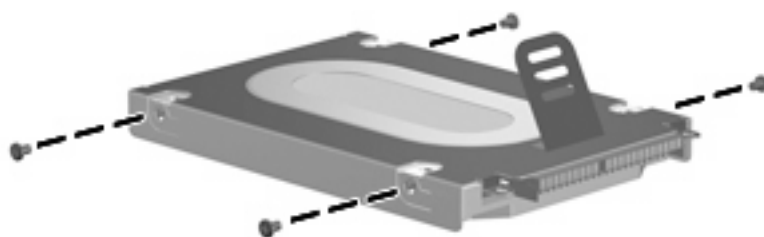

Where used: 4 screws that secure the hard drive bracket to the hard drive

Phillips PM2.0×3.0 screw

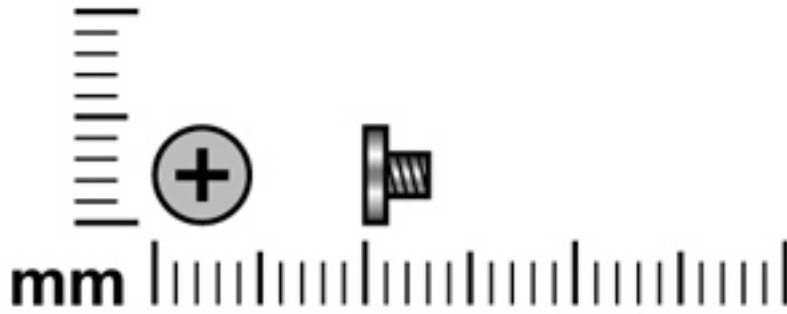

Color	Quantity	Length	Thread	Head diameter
Black	13	3.0 mm	2.0 mm	4.0 mm

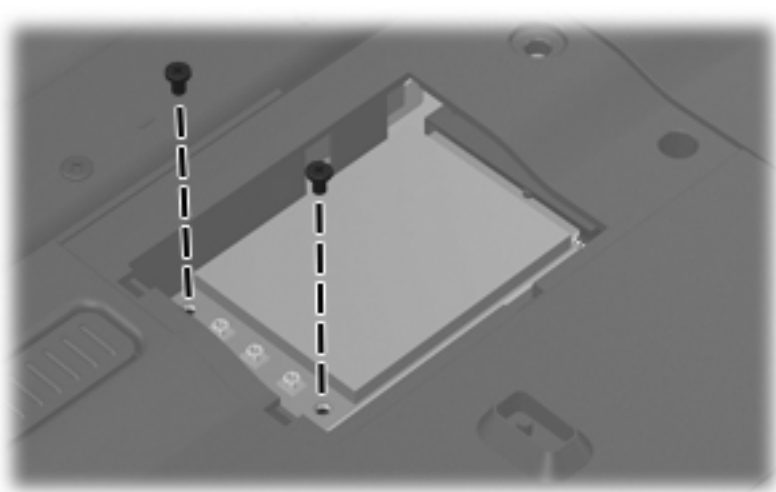

Where used: 2 screws that secure the WLAN module to the computer in the wireless module compartment

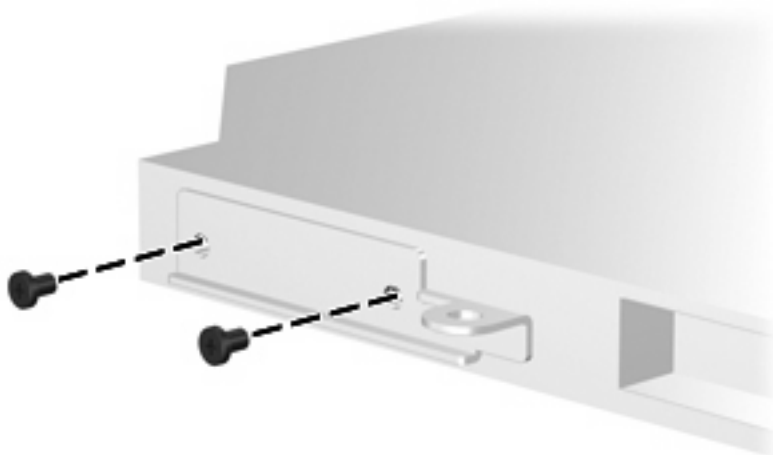

Where used: 2 screws that secure the optical drive bracket module to the optical drive

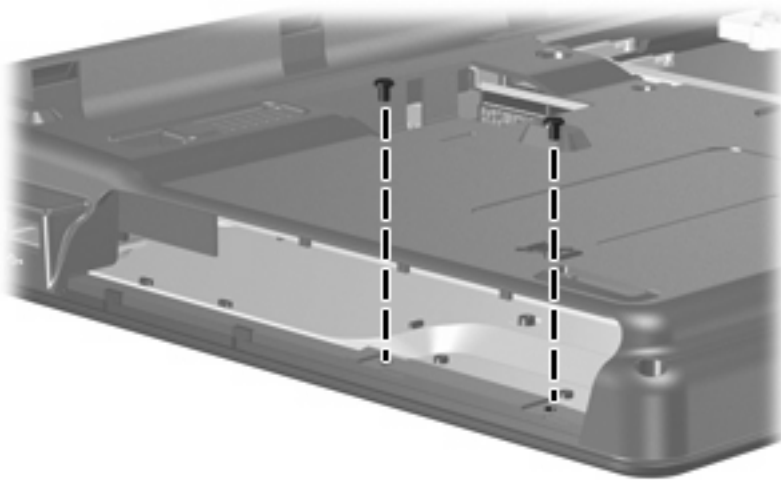

Where used: 2 screws that secure the top cover to the computer

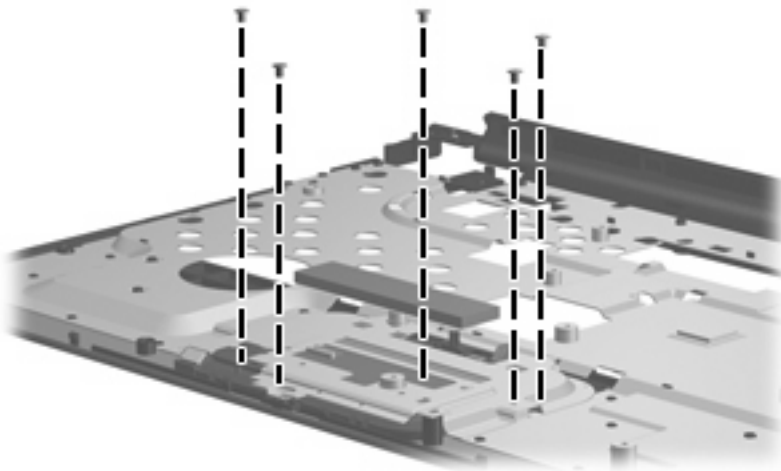

Where used: 5 screws that secure the TouchPad assembly to the top cover

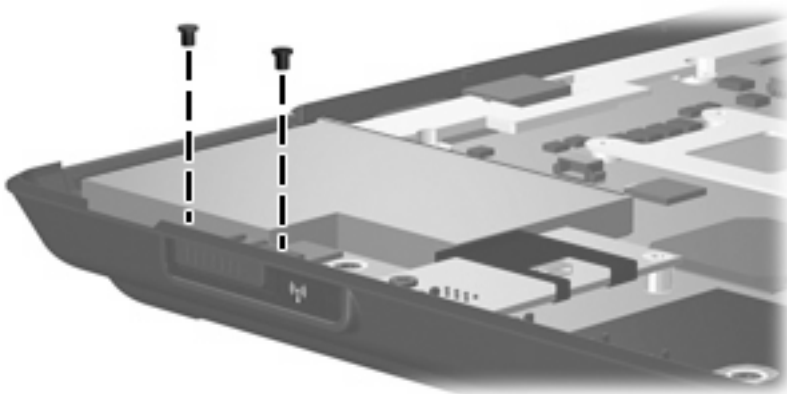

Where used: 2 screws that secure the wireless switch board to the computer

Phillips PM2.5×9.0 screw

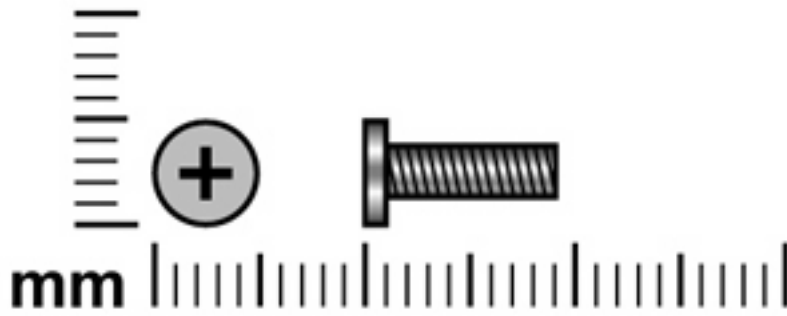

Color	Quantity	Length	Thread	Head diameter
Black	12	9.0 mm	2.5 mm	5.0 mm

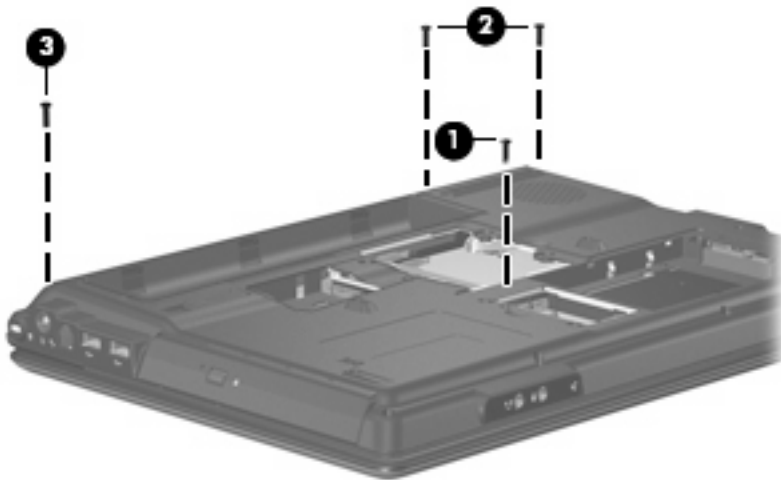

Where used:

- (1) One screw that secures the optical drive to the computer
- (2) Two screws that secure the switch cover to the computer
- (3) One screw that secures the display assembly to the computer

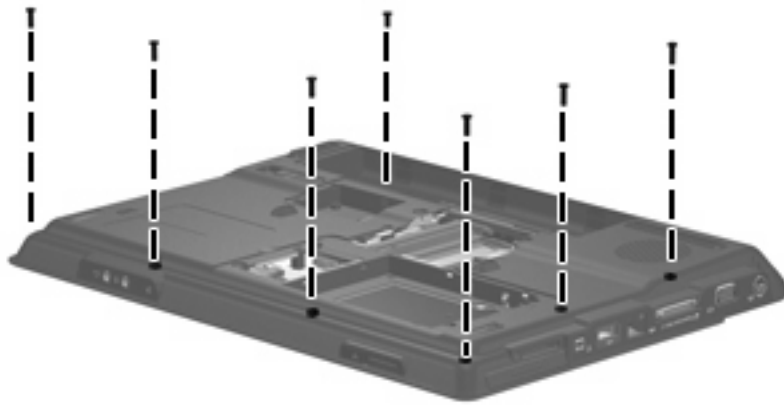

Where used: 7 screws that secure the top cover to the computer

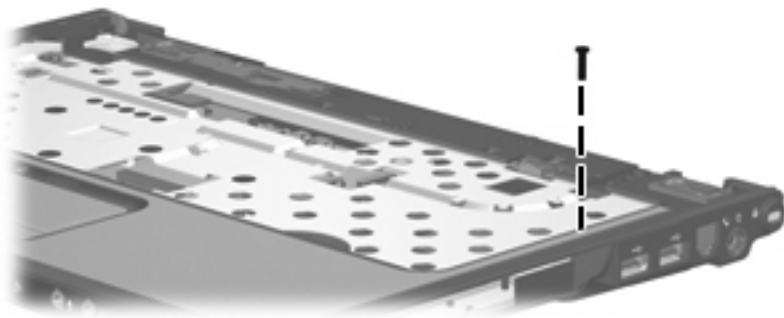

Where used: One screw that secures the top cover to the computer

Black Phillips PM2.5×7.0 screw

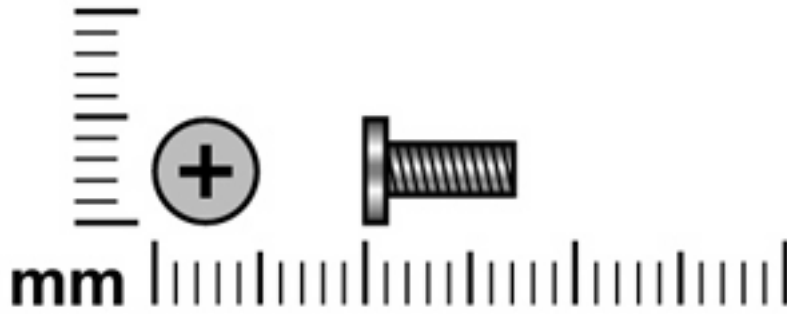

Color	Quantity	Length	Thread	Head diameter
Silver	16	7.0 mm	2.5 mm	5.0 mm

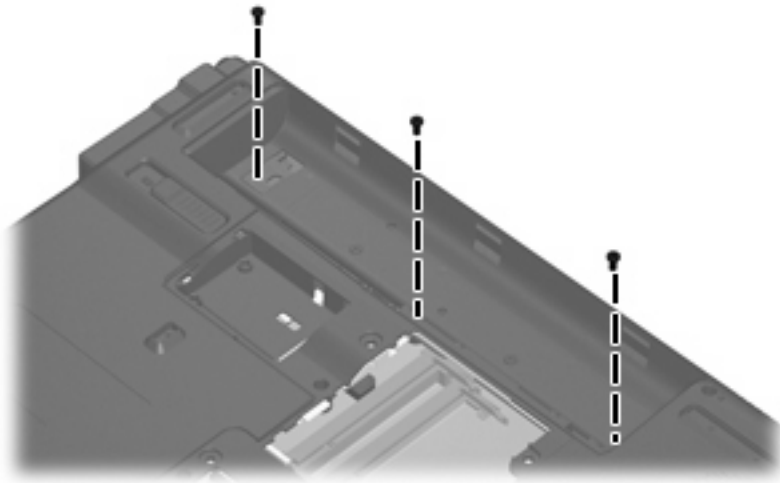

Where used: 3 screws that secure the keyboard to the computer



Where used: 5 screws that secure the display assembly to the computer

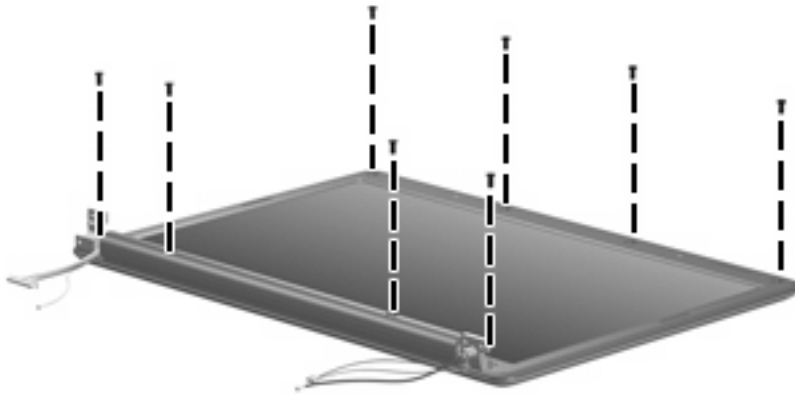

Where used: 8 screws that secure the display bezel to the display assembly

Black Phillips PM2.0×5.0 screw

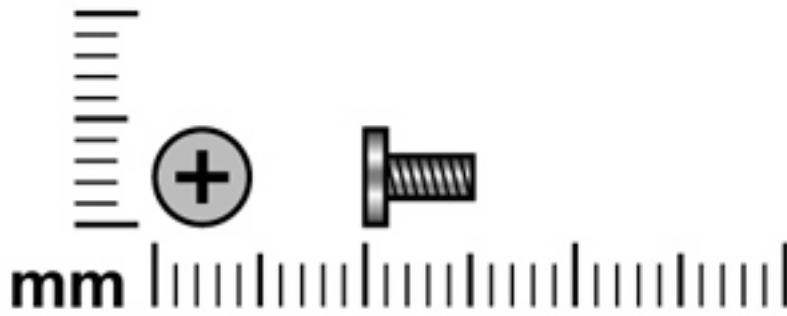

Color	Quantity	Length	Thread	Head diameter
Black	7	5.0 mm	2.0 mm	5.0 mm

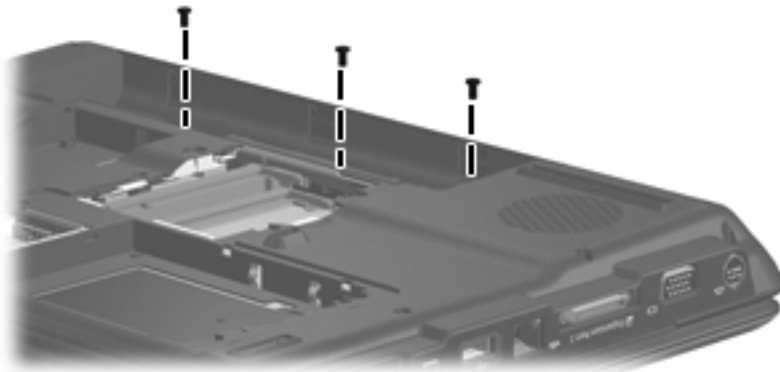

Where used: 3 screws that secure the switch cover to the computer

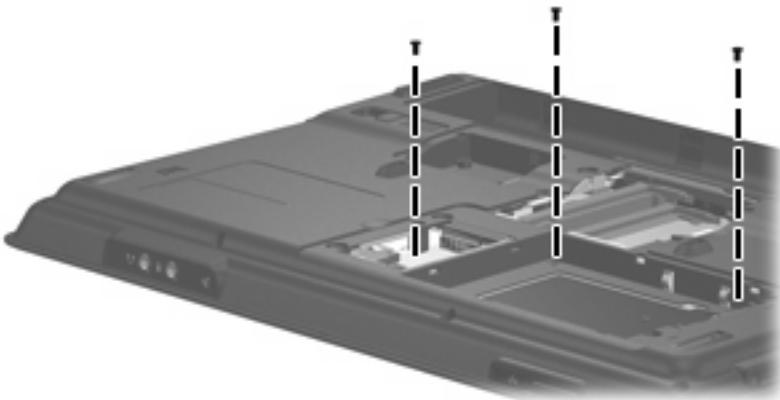

Where used: 3 screws that secure the top cover to the computer

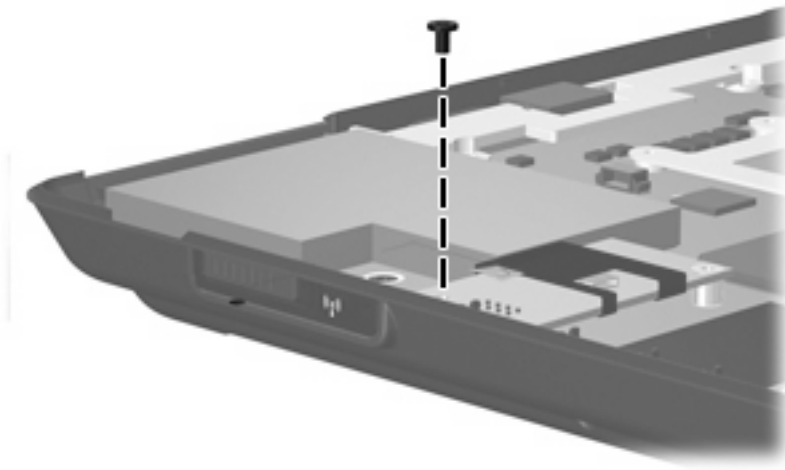

Where used: One screw that secures the modem module to the computer

Black Phillips PM2.5×5.0 screw

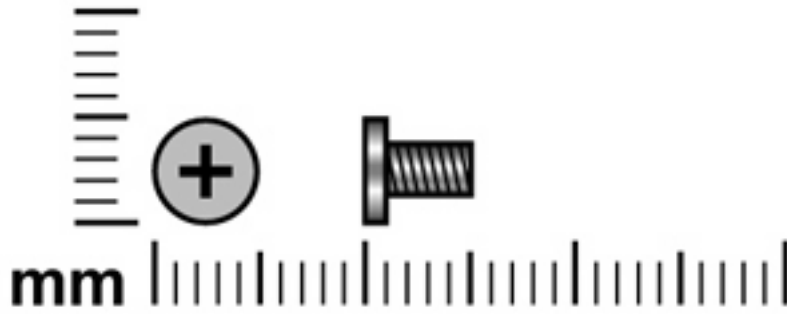

Color	Quantity	Length	Thread	Head diameter
Silver	9	5.0 mm	2.5 mm	5.0 mm

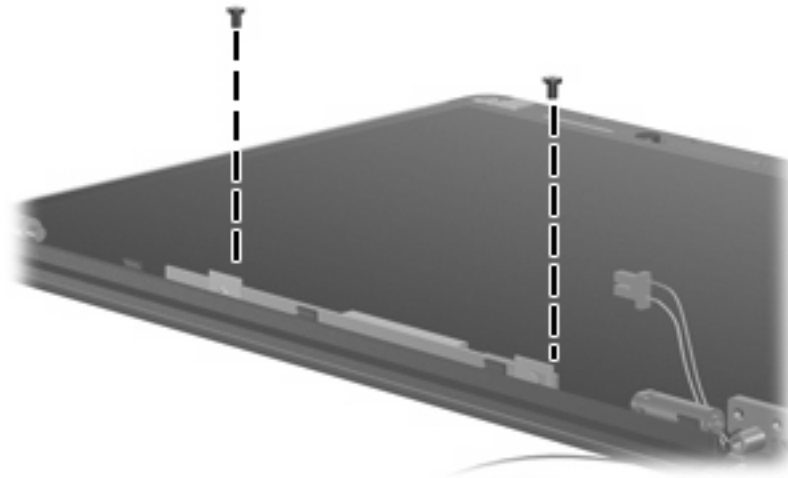

Where used: 2 screws that secure the display inverter to the display enclosure

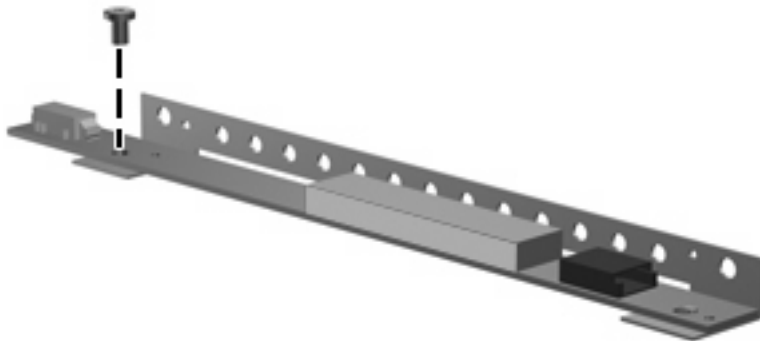

Where used: One screw that secures the display inverter to the display inverter bracket

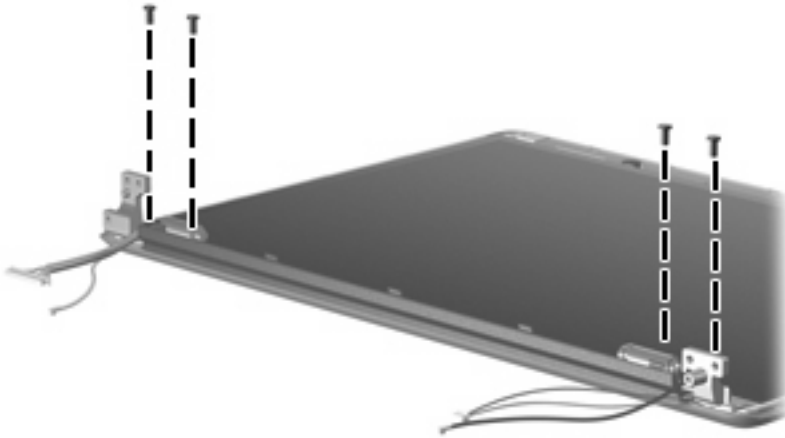

Where used: 4 screws that secure the display hinges to the display enclosure

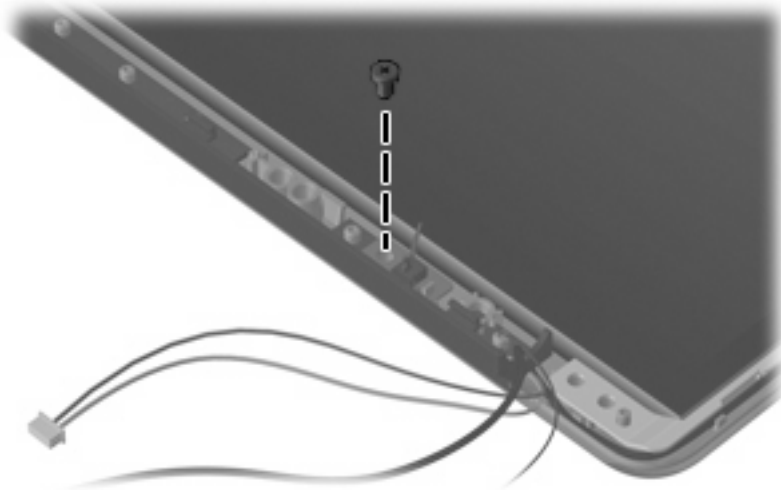

Where used: One screw that secures the display switch module to the display enclosure

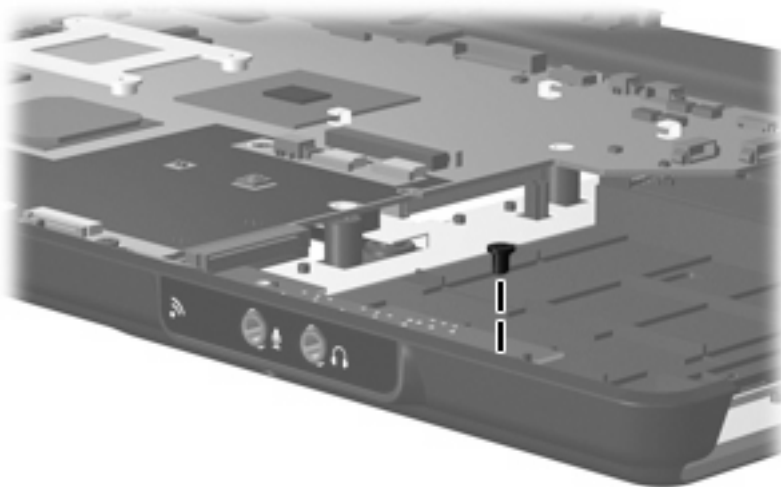

Where used: One screw that secures the audio board to the computer

Silver Phillips PM2.0×2.0 screw

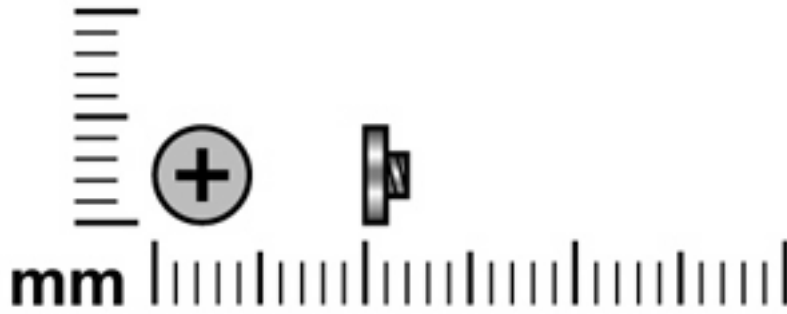

Color	Quantity	Length	Thread	Head diameter
Silver	2	2.0 mm	2.0 mm	3.5 mm

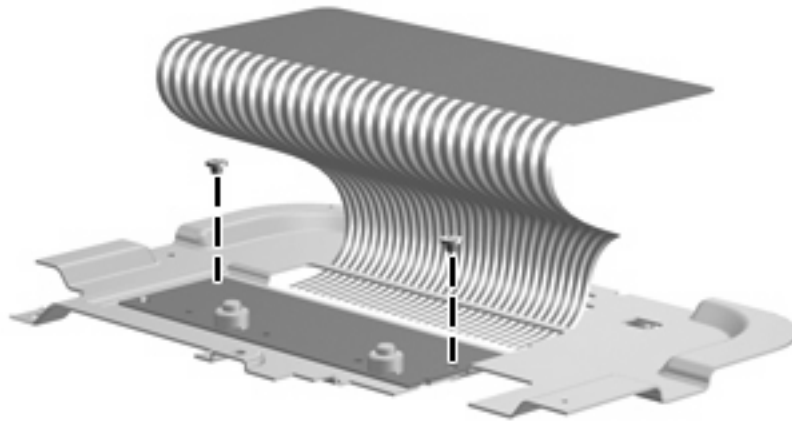

Where used: 2 screws that secure the TouchPad to the TouchPad bracket

Black Phillips PM2.0×4.0 screw

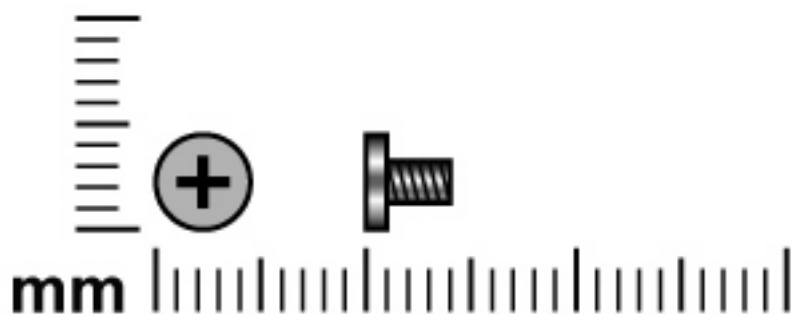

Color	Quantity	Length	Thread	Head diameter
Black	4	4.0 mm	2.0 mm	5.0 mm

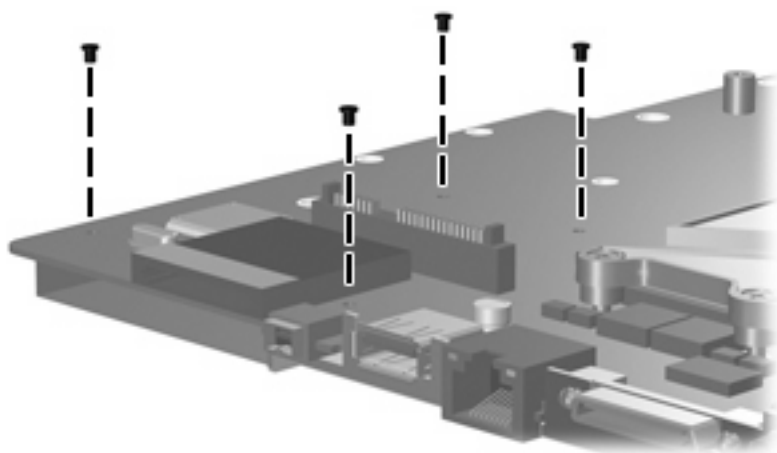

Where used: 4 screws that secure the ExpressCard assembly to the system board

Black Phillips PM2.0x3.0 screw

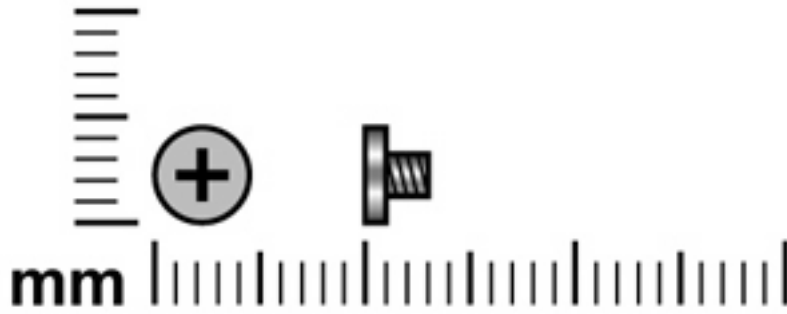

Color	Quantity	Length	Thread	Head diameter
Black	2	3.0 mm	2.0 mm	4.0 mm

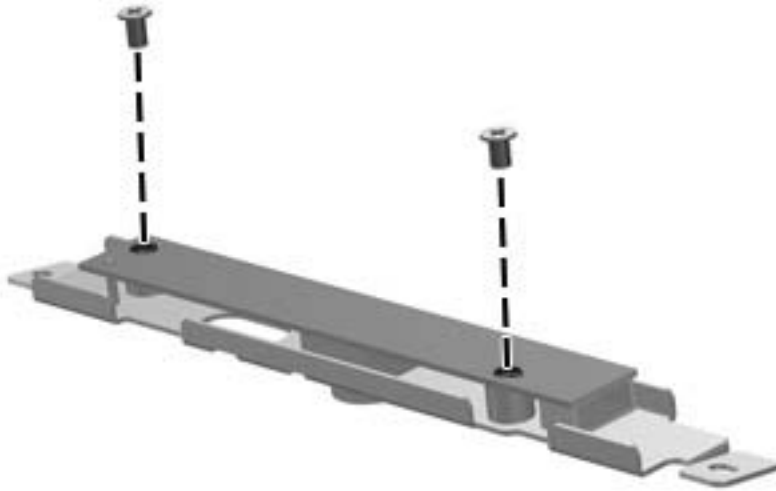

Where used: 2 screws that secure the camera module bracket to the camera module

Phillips PM2.0×13.0 captive screw

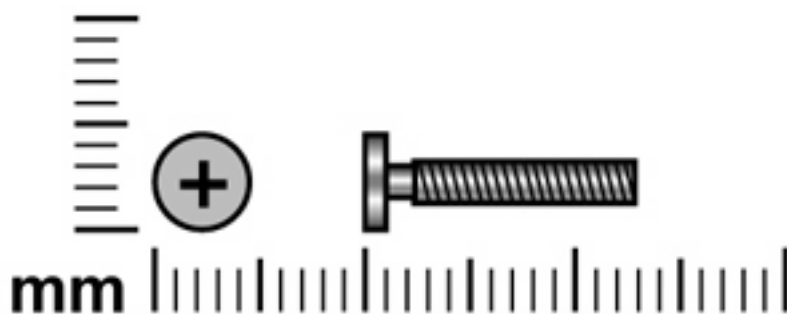

Color	Quantity	Length	Thread	Head diameter
Silver	4	13.0 mm	2.0 mm	5.0 mm

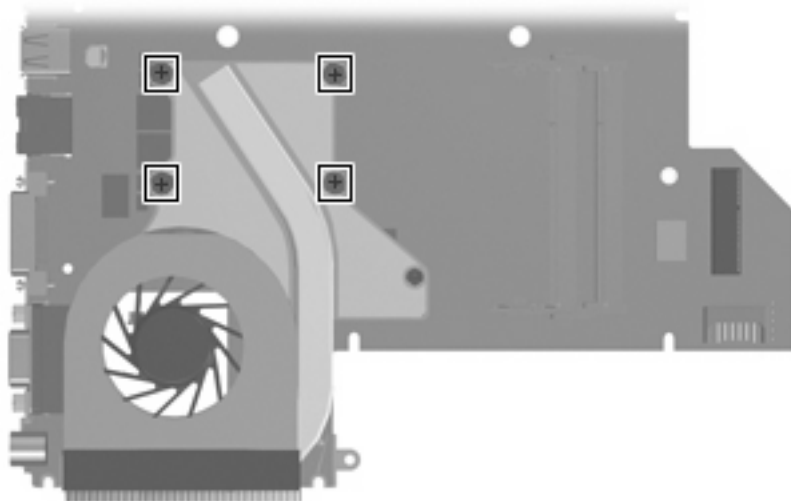

Where used: 4 captive screws that secure the fan/heat sink assembly to the system board (secured by C-clips)

8 Backup and Recovery

Recovering system information

Tools provided by the operating system and Recovery Manager software are designed to help you with the following tasks for safeguarding your information and restoring it in case of a system failure:

- Back up your information regularly to protect your important system files.
- Make a set of recovery discs (Recovery Manager software feature). Recovery discs are used to start up (boot) your computer and restore the operating system and software programs to factory settings in case of system failure or instability.
- Create system restore points (operating system feature). System restore points allow you to reverse undesirable changes to your computer by restoring the computer to an earlier state.
- Recover a program or driver (Recovery Manager software feature). This feature helps you reinstall a program or driver without performing a full system recovery.
- Perform a full system recovery (Recovery Manager software feature). With Recovery Manager, you can recover your full factory image if you experience system failure or instability. Recovery Manager works from a dedicated recovery partition on the hard drive or from recovery discs you create.

Backing up your information

When to back up

- On a regularly scheduled basis.

 **NOTE:** Set reminders to back up your information periodically.

- Before the computer is repaired or restored.
- Before you add or modify hardware or software.

Back up suggestions

- Create system restore points using the Windows System Restore feature.
- Store personal files in the Documents folder and back up these folders periodically.
- Back up templates stored in their associated programs.
- Save customized settings in a window, toolbar, or menu bar by taking a screen shot of your settings.

The screen shot can be a time saver if you have to reset your preferences.

To copy the screen and paste it into a word-processing document:

- a. Display the screen.
- b. Copy the screen:
 - To copy only the active window, press **alt+fn+prt sc**.
 - To copy the entire screen, press **fn+prt sc**.
- c. Open a word-processing document, and then select **Edit > Paste**.

Using system restore points

When you back up your system, you are creating a system restore point. A system restore point allows you to save and name a snapshot of your hard drive at a specific point in time. You can then recover back to that point if you want to reverse subsequent changes made to your system.

 **NOTE:** Recovering to an earlier restore point does not affect data files saved or e-mails created since the last restore point.

You also can create additional restore points to provide increased protection for your system files and settings.

When to create restore points

- Before you add or extensively modify software or hardware.
- Periodically, whenever the system is performing optimally.

 **NOTE:** If you revert to a restore point and then change your mind, you can reverse the restoration.

Create a system restore point

1. Select **Start > Control Panel > System and Maintenance > System**.
2. In the left pane, click **System protection**.
3. Click the **System Protection** tab.
4. Under Automatic restore points, select the disk for which you want to create a restore point.
5. Click **Create**.

The System Protection window opens.
6. Follow the on-screen instructions.

Restore to a previous date and time

To revert to a restore point (created at a previous date and time), when the computer was functioning optimally, follow these steps:

1. Select **Start > Control Panel > System and Maintenance > System**.
2. In the left pane, click **System protection**.
3. Click the **System Protection** tab.
4. Click the **System Restore** button, and then click **Next**.

The System Restore window opens.

5. Follow the on-screen instructions.

Creating recovery discs

Recovery Manager creates a set of recovery CDs or DVDs for the computer. Use recovery discs to restore the operating system and software programs to factory settings, in case of system failure or instability.

 **NOTE:** Handle these discs carefully and keep them in a safe place. The software allows the creation of only one set of recovery discs.

Note the following guidelines before creating recovery discs:

- You will need high quality CD-R, DVD-R, or DVD+R media (purchased separately).

 **NOTE:** Formatted DVD±RW discs and DVD±RW double-layer discs are not compatible with the Recovery Manager software.

- The computer must be connected to AC power during this process.
- Only one set of recovery discs can be created per computer.
- Number each disc before inserting it into the computer optical drive.
- If necessary, you can exit the program before you have finished creating the recovery discs. The next time you open Recovery Manager, you will be prompted to continue the disc creation process.

To create a set of recovery discs:

1. Select **Start > All Programs > Recovery Manager > Recovery Manager**.

Recovery Manager opens.

2. Click **Advanced Options**.

 **NOTE:** If you are operating the computer on battery power, you will be prompted to connect to AC power before you can go to the next step.

3. Click **Recovery disc creation**, and then click **Next**.
4. Follow the on-screen instructions.

Reinstalling software programs and drivers

If a program or driver preinstalled at the factory is accidentally erased or is damaged, Recovery Manager allows you to reinstall it.

 **NOTE:** Software not provided with this computer must be reinstalled from the disc provided by the manufacturer or downloaded from the manufacturer's Web site.

NOTE: Before reinstalling the program, be sure it is fully uninstalled.

Recovery Manager replaces corrupted system files and reinstalls deleted system files within the program.

- In most cases, if the program you are reinstalling is still on your computer, the reinstallation process does not affect your personal settings.
- In all cases, if a program has been deleted from your computer, the reinstallation process reinstalls the program or utility to the factory image but cannot restore your personal settings.

Reinstalling preinstalled programs and drivers

1. Remove the program or driver:

 **NOTE:** In some cases, drivers are not listed in the Programs and Features list. If the driver is not listed, it does not need to be removed.

- a. Select **Start > Control Panel > Programs > Uninstall a program**.
 - b. Right-click the program or driver you want to remove, and then click **Uninstall**.
2. Reinstall the program or driver:
 - a. Select **Start > All Programs > Recovery Manager > Recovery Manager**.
Recovery Manager opens.
 - b. Click **Advanced Options**.
 - c. Click either **Software program re-installation** or **Hardware driver re-installation**, and then click **Next**.
 - d. Follow the on-screen instructions.
 - e. Restart the computer if prompted.

Reinstalling programs from discs

1. Insert the disc into the optical drive.
2. When the installation wizard opens, follow the installation instructions on the screen.
3. Restart the computer if prompted.

Performing a recovery

Recovery Manager software allows you to repair or restore the system if you experience system failure or instability. Recovery Manager works from recovery discs that you create or from a dedicated recovery partition on the hard drive.

 **NOTE:** Windows has its own built-in repair features, such as System Restore and driver rollback capabilities. If you have not already tried these features, try them before using Recovery Manager.

NOTE: Recovery Manager only recovers software that was preinstalled at the factory. Software not provided with this computer must be reinstalled from the disc provided by the manufacturer or downloaded from the manufacturer's Web site.

Recovering from the recovery discs

To restore the system from the recovery discs:

1. Back up all personal files.
2. Insert the first recovery disc into the optical drive and restart the computer.
3. Follow the on-screen instructions.

Recovering from the partition on the hard drive

You can perform a recovery from the partition on the hard drive from either the Start button or [f11](#).

To restore the system from the partition, follow these steps:

1. Access Recovery Manager in either of the following ways:
 - Select **Start > All Programs > Recovery Manager > Recovery Manager**.
 - Restart the computer and press [f11](#) while the "Press <F11> for recovery" message is displayed on the screen. Then select **Recovery Manager**.

Recovery Manager opens.

2. Click **Advanced Options**.
3. Click **System recovery**, and then click **Next**.
4. Follow the on-screen instructions.

Deleting the recovery partition on the hard drive

The Recovery Manager Advanced Options menu provides the option of deleting the recovery partition, which will increase space on the hard drive. Delete the recovery partition only if you have already created recovery discs.

△ **CAUTION:** After you create the recovery discs, you can increase space on the hard drive by deleting the recovery partition. However, doing this is not recommended. If you delete this partition, you will lose any information that is on the partition, including Recovery Manager software. Thereafter, you must use the recovery discs to access Recovery Manager software.

To delete the recovery partition:

1. If you have not already created recovery discs, create them now.
2. Select **Start > All Programs > Recovery Manager > Recovery Manager**.
Recovery Manager opens.
3. Click **Advanced Options**.
4. Click **Remove recovery partition**, and then click **Next**.
5. Follow the on-screen instructions.

Updating reinstalled software

After you perform a system recovery, connect to the Internet to update all reinstalled software.

To access update links for the operating system and other software provided on your computer:

- ▲ Select **Start > Help and Support**.

To update optional software, follow the instructions provided by the software manufacturer. Some programs include an update feature you can access from a Help button or menu within the program.

9 Connector pin assignments

Audio-out (headphone)

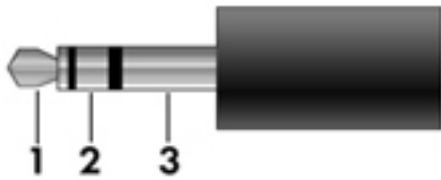

Pin	Signal
1	Audio out, left channel
2	Audio out, right channel
3	Ground

Audio-in (microphone)

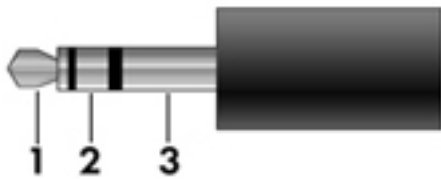

Pin	Signal
1	Audio signal in
2	Audio signal in
3	Ground

External monitor

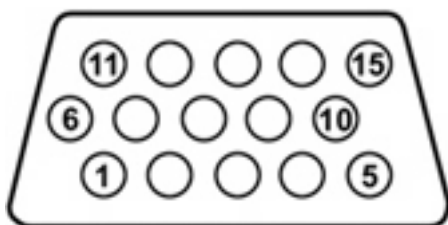

Pin	Signal
1	Red analog
2	Green analog
3	Blue analog
4	Not connected
5	Ground
6	Ground analog
7	Ground analog
8	Ground analog
9	+5 VDC
10	Ground
11	Monitor detect
12	DDC 2B data
13	Horizontal sync
14	Vertical sync
15	DDC 2B clock

RJ-11 (modem)

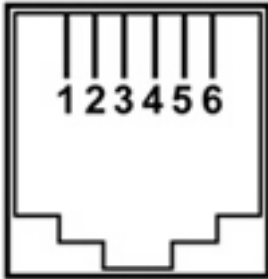

Pin	Signal
1	Unused
2	Tip
3	Ring
4	Unused
5	Unused
6	Unused

RJ-45 (network)

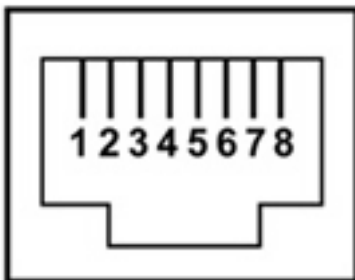

Pin	Signal
1	Transmit +
2	Transmit -
3	Receive +
4	Unused
5	Unused
6	Receive -
7	Unused
8	Unused

S-Video-out



Pin	Signal
1	S-VHS color (C) signal
2	Composite video signal
3	S-VHS intensity (Y) signal
4	S-VHS color ground
5	TV-CD
6	S-VHS intensity ground
7	Composite video ground

Universal Serial Bus

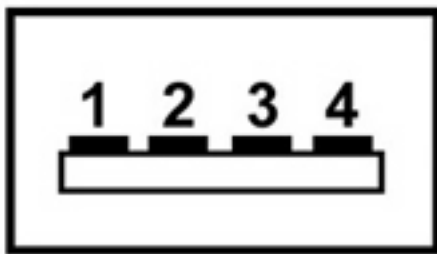

Pin	Signal
1	+5 VDC
2	Data -
3	Data +
4	Ground

10 Power cord set requirements

The wide range input feature of the computer permits it to operate from any line voltage from 100 to 120 volts AC or from 220 to 240 volts AC.

The 3-conductor power cord set included with the computer meets the requirements for use in the country or region where the equipment is purchased.

Power cord sets for use in other countries or regions must meet the requirements of the country or region where the computer is used.

Requirements for all countries or regions

The requirements listed below are applicable to all countries or regions:

- The length of the power cord set must be at least 1.5 m (5.0 ft) and no more than 2.0 m (6.5 ft).
- All power cord sets must be approved by an acceptable accredited agency responsible for evaluation in the country or region where the power cord set will be used.
- The power cord sets must have a minimum current capacity of 10 amps and a nominal voltage rating of 125 or 250 V AC, as required by each country or region's power system.
- The appliance coupler must meet the mechanical configuration of an EN 60 320/IEC 320 Standard Sheet C13 connector for mating with the appliance inlet on the back of the computer.

Requirements for specific countries or regions

Country/region	Accredited agency	Applicable note number
Australia	EANSW	1
Austria	OVE	1
Belgium	CEBC	1
Canada	CSA	2
Denmark	DEMKO	1
Finland	FIMKO	1
France	UTE	1
Germany	VDE	1
Italy	IMQ	1
Japan	METI	3
The Netherlands	KEMA	1
Norway	NEMKO	1
The People's Republic of China	CCC	5
South Korea	EK	4
Sweden	SEMKO	1
Switzerland	SEV	1
Taiwan	BSMI	4
The United Kingdom	BSI	1
The United States	UL	2

1. The flexible cord must be Type HO5VV-F, 3-conductor, 1.0-mm² conductor size. Power cord set fittings (appliance coupler and wall plug) must bear the certification mark of the agency responsible for evaluation in the country or region where it will be used.
2. The flexible cord must be Type SPT-3 or equivalent, No. 18 AWG, 3-conductor. The wall plug must be a two-pole grounding type with a NEMA 5-15P (15 A, 125 V) or NEMA 6-15P (15 A, 250 V) configuration.
3. The appliance coupler, flexible cord, and wall plug must bear a "T" mark and registration number in accordance with the Japanese Dentori Law. The flexible cord must be Type VCT or VCTF, 3-conductor, 1.00-mm² conductor size. The wall plug must be a two-pole grounding type with a Japanese Industrial Standard C8303 (7 A, 125 V) configuration.
4. The flexible cord must be Type RVV, 3-conductor, 0.75-mm² conductor size. Power cord set fittings (appliance coupler and wall plug) must bear the certification mark of the agency responsible for evaluation in the country or region where it will be used.
5. The flexible cord must be Type VCTF, 3-conductor, 0.75-mm² conductor size. Power cord set fittings (appliance coupler and wall plug) must bear the certification mark of the agency responsible for evaluation in the country or region where it will be used.

11 Recycling

Battery

When a battery has reached the end of its useful life, do not dispose of the battery in general household waste. Follow the local laws and regulations in your area for computer battery disposal.

Display

- ⚠ **WARNING!** The backlight contains mercury. Caution must be exercised when removing and handling the backlight to avoid damaging this component and causing exposure to the mercury.
- ⚠ **CAUTION:** The procedures in this appendix can result in damage to display components. The only components intended for recycling purposes are the liquid crystal display (LCD) panel and the backlight. Careful handling must be exercised when removing these components.
- 📄 **NOTE: Materials Disposal.** This HP product contains mercury in the backlight in the display assembly that might require special handling at end-of-life. Disposal of mercury may be regulated because of environmental considerations. For disposal or recycling information, contact your local authorities, or see the Electronic Industries Alliance (EIA) Web site at <http://www.eiae.org>.

This section provides disassembly instructions for the display assembly. The display assembly must be disassembled to gain access to the backlight **(1)** and the liquid crystal display (LCD) panel **(2)**.



- 📄 **NOTE:** The procedures provided in this appendix are general disassembly instructions. Specific details, such as screw sizes, quantities, and locations, and component shapes and sizes, can vary from one computer model to another.

Perform the following steps to disassemble the display assembly:

1. Remove all screw covers **(1)** and screws **(2)** that secure the display bezel to the display assembly.

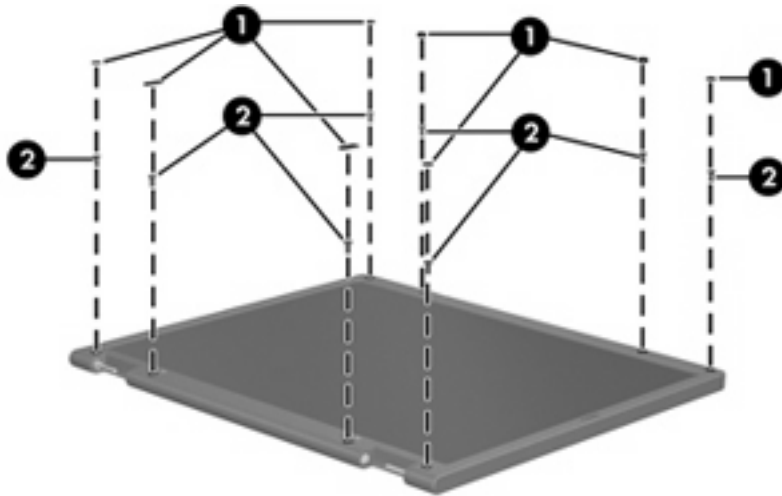

2. Lift up and out on the left and right inside edges **(1)** and the top and bottom inside edges **(2)** of the display bezel until the bezel disengages from the display assembly.
3. Remove the display bezel **(3)**.

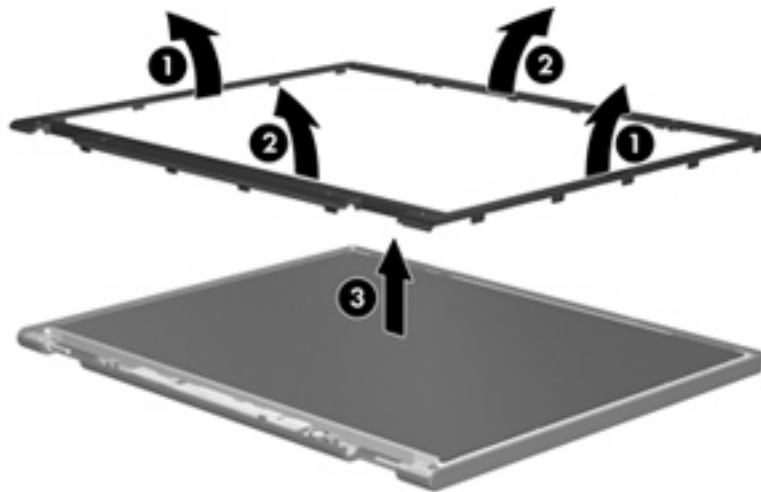

4. Disconnect all display panel cables **(1)** from the display inverter and remove the inverter **(2)**.

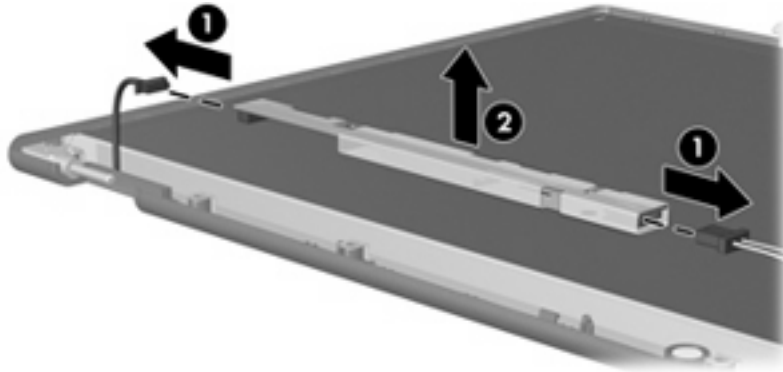

5. Remove all screws **(1)** that secure the display panel assembly to the display enclosure.
6. Remove the display panel assembly **(2)** from the display enclosure.

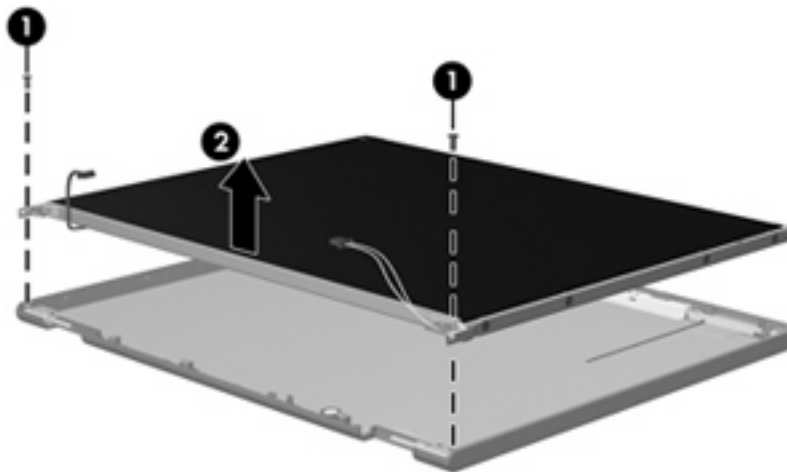

7. Turn the display panel assembly upside down.
8. Remove all screws that secure the display panel frame to the display panel.

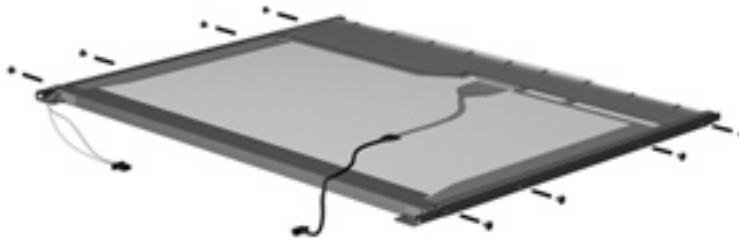

9. Use a sharp-edged tool to cut the tape **(1)** that secures the sides of the display panel to the display panel frame.

10. Remove the display panel frame **(2)** from the display panel.

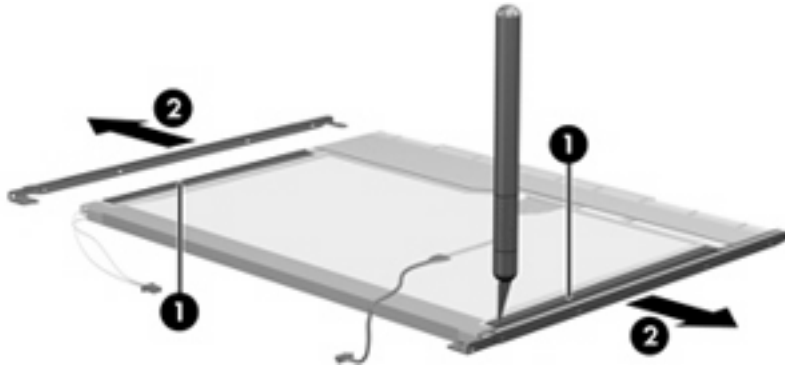

11. Remove the screws **(1)** that secure the backlight cover to the display panel.
12. Lift the top edge of the backlight cover **(2)** and swing it outward.

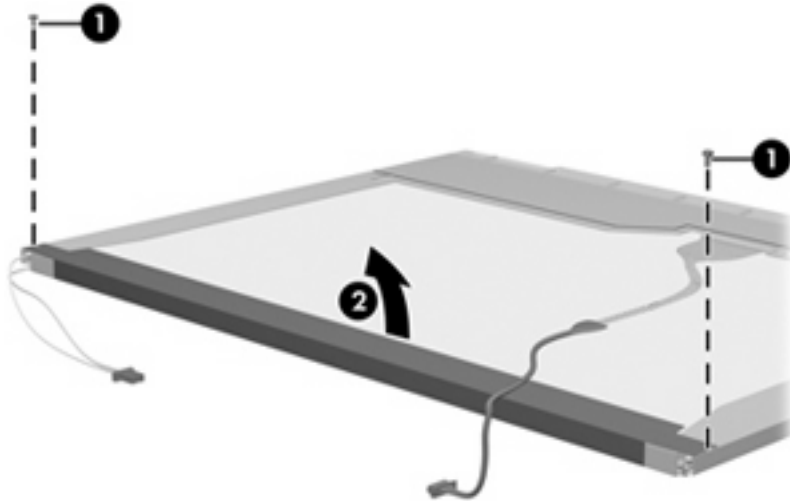

13. Remove the backlight cover.
14. Turn the display panel right-side up.

15. Remove the backlight cables (1) from the clip (2) in the display panel.

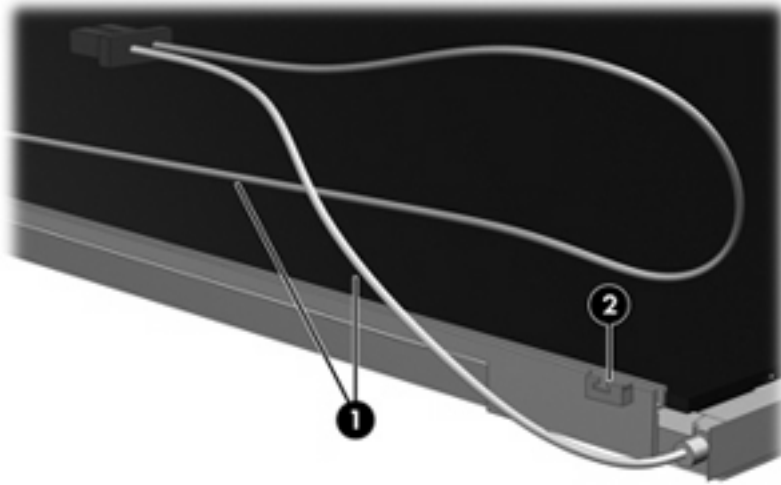

16. Turn the display panel upside down.
17. Remove the backlight frame from the display panel.

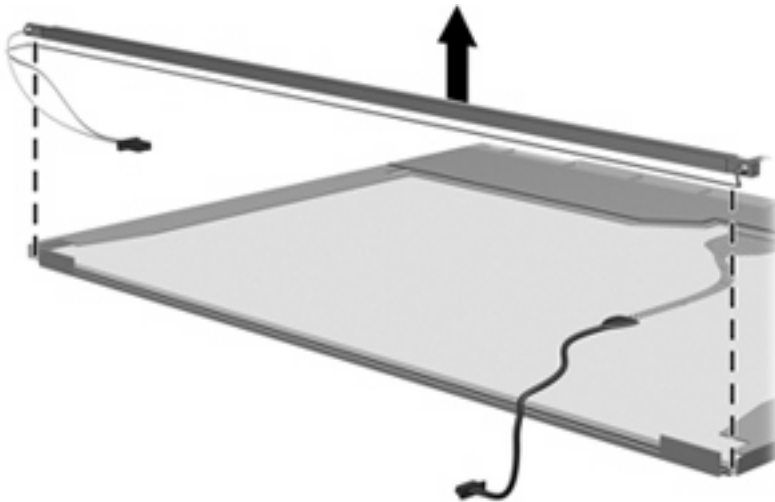

⚠ WARNING! The backlight contains mercury. Exercise caution when removing and handling the backlight to avoid damaging this component and causing exposure to the mercury.

18. Remove the backlight from the backlight frame.

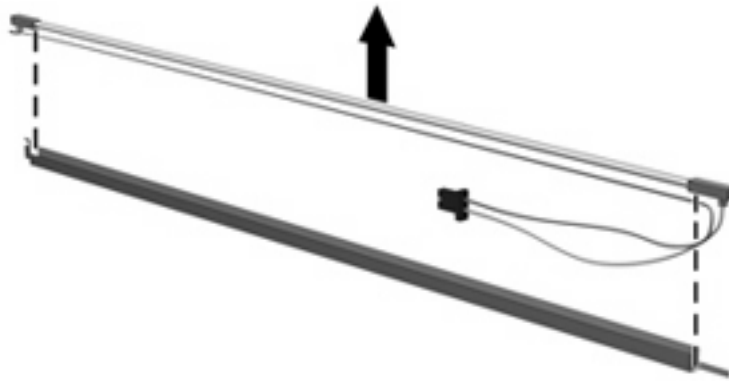

19. Disconnect the display cable (1) from the LCD panel.
20. Remove the screws (2) that secure the LCD panel to the display rear panel.
21. Release the LCD panel (3) from the display rear panel.
22. Release the tape (4) that secures the LCD panel to the display rear panel.

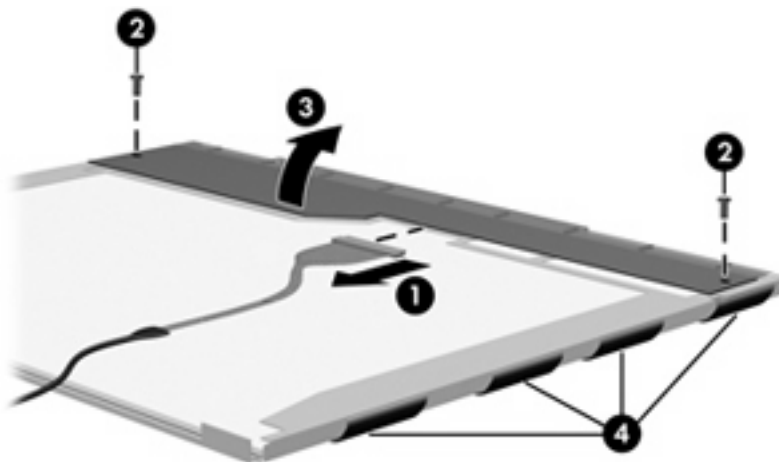

23. Remove the LCD panel.

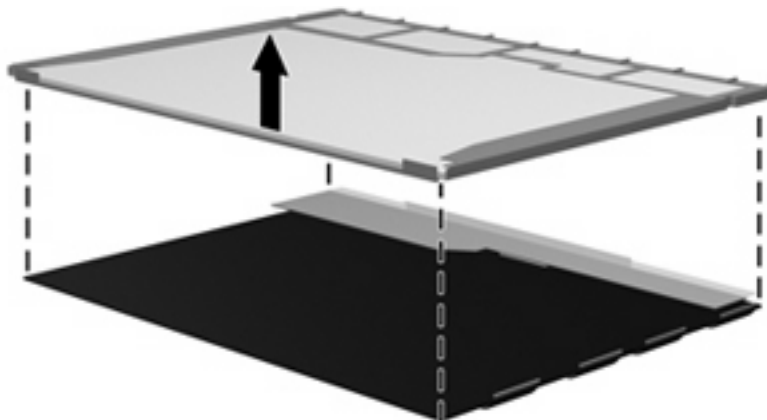

24. Recycle the LCD panel and backlight.

Index

Symbols/Numerics

1394 port, location 14

A

AC adapter, spare part
numbers 34, 36, 37
administrator password 109
advanced Setup Utility
features 108
antenna
removal 76
spare part number 28, 37,
77
antenna, microphone cable kit
spare part number 42, 43
applications key, Windows 10
audio board
removal 88
spare part number 21, 40,
42, 44, 88
audio, product description 5
audio-in jack
location 13
pin assignments 150
audio-out jack
location 13
pin assignments 150

B

backpack, spare part
number 34, 36
backup 144
base enclosure, spare part
number 23, 37, 42, 43
battery
location 17
removal 53
spare part numbers 23, 38,
40, 53
battery bay 17

battery light 11
battery release latch 17
bezel
illustrated 27
spare part number 27, 39,
42, 43, 74
Bluetooth module
removal 89
spare part number 23, 36,
89
Bluetooth module cable
spare part number 42
Bluetooth module cable,
illustrated 31
boot options 109
boot order 109
bottom components 17
button components 9
button sound 109
buttons
media 9
power 9
volume mute 9

C

Cable Kit
contents 31
spare part number 27, 31,
37
cables, service considerations 46
camera
product description 5
camera module
removal 77
spare part number 77
spare part numbers 41
caps lock light 11
carrying case, spare part
number 34, 37
changing the Setup Utility
language 106
chipset, product description 2
closing the Setup Utility 108
CMOS clearing 50
components
bottom 17
button 9
display 8
front 8, 13
key 10
left-side 14
lights 11
rear 15
right-side 16
TouchPad 12
composite audio and S-Video cable,
spare part number 34
composite video cable 36
computer feet
locations 52
spare part number 23, 37,
52
computer specifications 111
connector pin assignments
audio-in 150
audio-out 150
external monitor 151
headphone 150
microphone 150
modem 152
monitor 151
network 152
RJ-11 152
RJ-45 152
S-Video-out 153
Universal Serial Bus (USB) 153
connectors, service
considerations 46

D

dedicated video memory 109
Diagnostics menu 109
Digital Media Slot 14
Digital Media Slot light 14
diskette drive
 precautions 46
 product description 5
display assembly
 removal 71
 spare part number 19, 39,
 40, 42, 43, 71
display bezel
 illustrated 27
 spare part number 27, 39,
 42, 43, 74
display bracket
 spare part number 41
Display Cable Kit, spare part
 number 28, 39, 42
display components
 illustrated 27
 recycling 156
 spare part numbers 27
display enclosure
 illustrated 27
 spare part number 28, 39,
 41, 42, 43
display hinge
 illustrated 28
 removal 75
 spare part number 28, 37,
 41, 75
Display Hinge Kit, spare part
 number 28
display inverter
 illustrated 27
 spare part number 28, 37,
 41
display panel
 illustrated 27
 product description 4
 removal 76
 spare part number 28, 39,
 41, 76
Display Screw Kit, spare part
 number 28, 37, 42
display specifications 112
display switch 8

display switch module
 illustrated 28
 removal 75
 spare part number 28
 spare part numbers 37
docking support, product
 description 6
Door/Cover Kit
 contents 30
 spare part number 21, 30
drive light 11
drivers, reinstalling 147
drives
 boot order 109
 preventing damage 46
DVB-T antenna adapter, spare part
 number 34, 36
DVB-T antenna and DVB-T antenna
 adapter, spare part number 36
DVB-T tuner, spare part
 number 34, 36
DVD/CD-RW Combo Drive
 precautions 46
 removal 64
 spare part number 27, 32,
 40, 41, 64
 specifications 114
DVD±RW and CD-RW Combo Drive
 precautions 46
 removal 64
 spare part numbers 27, 32,
 40, 41, 64
 specifications 114

E

electrostatic discharge 47
esc key 10
Ethernet, product description 5
expansion port 3 14
ExpressCard assembly
 removal 97
 spare part number 21, 37,
 97
ExpressCard slot 14
ExpressCard slot bezel
 illustrated 30
external media cards, product
 description 6

external monitor port
 location 14
 pin assignments 151

F

fan/heat sink assembly
 removal 100
 spare part number 23, 40,
 42, 100
fan/heat sink assembly mounting
 bracket
 installation 102
 spare part number 102
fan/heat sink mounting bracket
 spare part number 23, 37
feet
 locations 52
 spare part number 23, 37,
 52
fingerprint reader
 spare part number 42
fn key 10
front components 8, 13
function keys 10

G

graphics, product description 3
grounding equipment and
 methods 49

H

hard drive
 precautions 46
 product description 4
 removal 54
 spare part numbers 23, 32,
 40, 41, 43, 54
 specifications 113
hard drive bay 17
hard drive cover
 illustrated 30
 removal 55
hard drive hardware kit
 spare part numbers 24, 32,
 41
hard drive self test 109
headphone jack
 location 13
 pin assignments 150
headset, spare part number 34

hinge
 illustrated 28
 removal 75
 spare part number 28, 37, 41, 75

HP slipcase
 spare part number 42

I

I/O address specifications 118, 120

infrared emitter, spare part number 34, 37

infrared lens 13

interrupt specifications 116, 117

inverter
 illustrated 27
 removal 74
 spare part number 28, 37, 41, 74

J

jacks
 audio-in 13
 audio-out 13
 headphone 13
 microphone 13
 modem 16
 network 14
 RJ-11 16
 RJ-45 14
 S-Video-out jack 14

K

key components 10

keyboard
 product description 6
 removal 66
 spare part numbers 20, 39, 66

keypad keys 10

keys
 esc 10
 fn 10
 function 10
 Windows applications 10
 Windows logo 10

L

language support 106, 109

LED board cable, illustrated 31

left-side components 14

light components 11

lights
 battery 11
 caps lock 11
 drive 11
 media button 11
 num lock 11
 power 11
 volume down 11
 volume mute 11
 volume up 11
 wireless 13

M

main menu 108

mass storage devices, spare part numbers 32

media button 9

media button light 11

memory map specifications 122, 123

memory module
 product description 4
 removal 62
 spare part numbers 24, 40, 62

memory module compartment 17

memory module compartment cover
 illustrated 30
 removal 62
 spare part number 62

memory test 110

microphone
 location 8
 product description 5
 removal 77

microphone jack
 location 13
 pin assignments 150

model name 1

modem jack
 location 16
 pin assignments 152

modem module
 product description 5
 removal 87
 spare part number 21, 44, 87

modem module cable
 illustrated 31
 removal 97
 spare part number 42

monitor port
 location 14
 pin assignments 151

mouse, spare part numbers 34, 37

N

navigating in the Setup Utility 107

network jack
 location 14
 pin assignments 152

num lock light 11

O

operating system, product description 7

optical drive
 location 16
 precautions 46
 product description 4
 removal 64
 spare part numbers 27, 32, 64
 specifications 114

P

packing guidelines 48

password clearing 50

passwords 109

plastic parts 45

pointing device
 components 12
 product description 6

ports
 1394 14
 external monitor port 14
 monitor port 14
 product description 6
 Universal Serial Bus (USB) 14, 16

power button 9

power button board cable, illustrated 31

power connector 16

- power connector cable
 - removal 94
 - spare part number 23, 37, 40, 94
- power cord set requirements 154
- power cord, spare part numbers 34, 35
- power light 11
- power requirements, product description 6
- power-on password 109
- processor
 - product description 1
 - removal 103
 - spare part numbers 22, 39, 40, 103
- product description
 - audio 5
 - camera 5
 - chipset 2
 - diskette drive 5
 - display panel 4
 - docking support 6
 - Ethernet 5
 - external media cards 6
 - graphics 3
 - hard drives 4
 - keyboard 6
 - memory module 4
 - microphone 5
 - modem module 5
 - operating system 7
 - optical drives 4
 - pointing devices 6
 - ports 6
 - power requirements 6
 - processors 1
 - product name 1
 - security 7
 - serviceability 7
 - wireless 5
- product name 1
- R**
- rear components 15
- recovery discs 146
- recovery partition, deleting 149
- recovery, system 148
- remote control, spare part numbers 34, 36, 37
- removal/replacement
 - preliminaries 45
 - procedures 51
- restore points 145
- RF input adapter cable without ferrite 36
- RF input adapter cable, spare part number 34
- right-side components 16
- RJ-11 jack
 - location 16
 - pin assignments 152
- RJ-45 jack
 - location 14
 - pin assignments 152
- RTC battery
 - removal 61
 - spare part number 24, 36, 61
- rubber display kit
 - spare part number 42
- Rubber Feet Kit, spare part number 23, 37, 52
- S**
- S-Video-out jack
 - location 14
 - pin assignments 153
- Screw Kit
 - contents 125
 - spare part number 35, 37, 42
- screw listing 125
- secondary hard drive self test 109
- security cable slot 16
- Security menu 109
- security, product description 7
- selecting in the Setup Utility 107
- serial number 18, 51
- service considerations 45
- serviceability, product description 7
- Setup Utility
 - changing the language 106
 - Diagnostics menu 109
 - displaying system information 107
 - Main menu 108
 - navigating 107
 - overview 106
- Security menu 109
 - selecting 107
 - starting 106
 - System Configuration menu 109
 - using advanced features 108
- software
 - reinstalling 147
 - updating 149
- speaker assembly
 - removal 92
 - spare part number 21, 36, 92
- speakers 9
- specifications
 - computer 111
 - display 112
 - DVD/CD-RW Combo Drive 114
 - DVD±RW and CD-RW Combo Drive 114
 - hard drive 113
 - I/O addresses 118, 120
 - interrupts 116, 117
 - memory map 122, 123
 - optical drive 114
 - system DMA 115
- static-shielding materials 49
- switch cover
 - removal 69
 - spare part number 20, 36, 40, 69
- system board
 - removal 95
 - spare part numbers 21, 39, 41, 43, 44, 95
- System Configuration menu 109
- system DMA 115
- system information 107, 108
- system memory map 122, 123
- T**
- thermal paste, replacement 101
- tools required 45
- top components 9
- top cover
 - removal 80
 - spare part number 20, 37, 40, 42, 43, 80

- TouchPad
 - removal 83
 - spare part number 21, 40, 42, 83
- TouchPad components
 - left button 12
 - light 12
 - on/off button 12
 - right button 12
 - scroll zone 12
 - TouchPad 12
- transporting guidelines 48
- TV tuner antenna, spare part number 34, 37
- TV tuner remote control, spare part number 36
- TV tuner, spare part number 34, 37
- Wireless Antenna Kit, spare part number 28, 37, 77
- wireless light 13
- wireless module compartment 17
- wireless module compartment cover
 - illustrated 30
 - removal 59
- wireless switch 13
- wireless switch board
 - removal 85
 - spare part number 21, 37, 85
- wireless, product description 5
- WLAN module
 - removal 57
 - spare part numbers 24, 36, 38, 40, 42, 43, 57
- workstation guidelines 48

U

- Universal Serial Bus (USB) port
 - locations 14, 16
 - pin assignments 153
- unknown password 50
- USB board
 - removal 90
 - spare part number 23, 36, 42, 90
- USB digital drive, spare part number 34, 35
- USB infrared receiver, spare part number 36
- USB/power connector board cable
 - illustrated 31

V

- vents 15, 17
- Virtualization Technology 109
- volume down light 11
- volume mute button 9
- volume mute light 11
- volume scroll zone 9
- volume up light 11

W

- Windows applications key 10
- Windows logo key 10
- wireless antenna
 - removal 76
 - spare part number 28, 37, 77

